



Si3452MS8 EVALUATION BOARD USER'S GUIDE

1. Introduction

The Si3452MS8 8-port evaluation kit (Si3452MS8-KIT) is intended for Power over Ethernet (PoE) Power Sourcing Equipment (PSE) system designers interested in evaluating the Quad-port Si3452 PSE controller. While evaluation kits are normally shipped with Si3452 devices that use Silicon Laboratories' proprietary dV/dt™ disconnect, they can also be used for evaluation of the pin-compatible Si3453, which uses dc disconnect. In this case, the Si3452 devices must be replaced with the appropriate Si3453 device. Please refer to "8. Ordering Guide" on page 35 for more information.

The Si3452 is controlled through an I²C (or SMBus) interface. For convenience in evaluation, a graphical user interface (GUI) is provided, giving an easy-to-use visual display and control of the Si3452 I²C registers. The evaluation kit assumes the user has access to a PC to control the evaluation board with the provided GUI.

The user is also responsible for providing an appropriate high-voltage power supply. The power supply should be 45 to 57 V for normal PoE or 51 to 57 V for PoE+. The Si3452 can supply over 30 W to each port. Thus, the two Si3452 controllers for the eight port demo system can provide over 240 W of total power. Normally, a 50 to 100 W power supply is used. While the classification and actual current consumption of each port is available, the demo GUI does not implement system-level power management. Contact Silicon Laboratories for more information about system-level power management options.

The Si3452MS8 kit has been thoroughly tested for standards compliance and interoperability. Contact Silicon Laboratories for test reports using Sifos PoE test equipment and University of New Hampshire PoE standards compliance and interoperability reports.

Si3452MS8-KIT

2. Kit Contents

This user's guide includes instructions on the use of the Si3452 register control GUI. An optional Power Manager GUI is described in the Si3452 Power Manager GUI user's guide on the CD-ROM. The installation instructions for the hardware and USB to I²C driver in this user's guide must be followed before installing and using the Si3452 Power Manager GUI.

Table 1. Evaluation Kit Contents

Kit	Contents
Si3452MS8-EB r1.1	The Si3452 8-port evaluation board with connector for an external 50 V power supply. The power supply must be capable of supplying the required amount of power for all PoE loads being connected. Standard boards are populated with Si3452-B01-GM parts.
Si3452CB-EB r1.1	An RJ-45 connector board configured as power over Ethernet Gigabit mid-span injector.
	A 24-wire cable to connect the Si3452 evaluation board to the mid-span injector board
PoE USB v1.3	A USB to I ² C (or SMBus) evaluation board. This board is preconfigured with updated firmware to support I ² C transactions.
	A USB cable to connect to a host PC
Si3402ISO-EB	A PD evaluation board configured to provide a Class 3 signature.
Si3402ISO-C4-EB	A PD evaluation board configured to provide a Class 4 signature.
	10 Ω loads for the evaluation boards. Each load will consume 2.5 W, which is about 3 W referred to the PSE side.
	Two Ethernet cables to connect the Si3400 and Si3401 evaluation boards to the connector board.
CD-ROM	Software drivers for the USB to SMBus adapter and a GUI for the Si3452 registers on a CD-ROM. Applicable applications notes and data sheets are also included.

3. Installation

Before you can use the Si3452 Monitor, you must first install the PoEUSB device driver associated with the PoEUSB adapter card, as well as install the Si3452 Monitor.

3.1. Installing the PoEUSB Device

If you have previously installed the PoEUSB device, uninstall the previous driver version before installing the new version. To uninstall the previous version, select “Programs and Features” or “Add or Remove Programs” from the Control Panel, and then uninstall “Windows Driver Package - Silicon Labs...”.

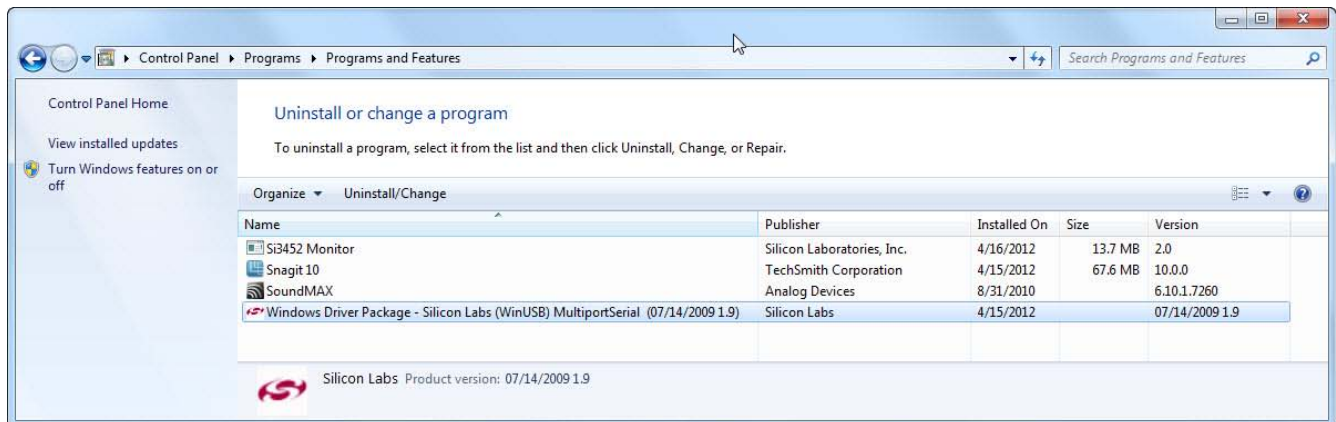

Figure 1. Uninstall Previous Rev Windows Driver Package

To install the PoEUSB device driver, run PoEUSBSetup_v1.1.exe.

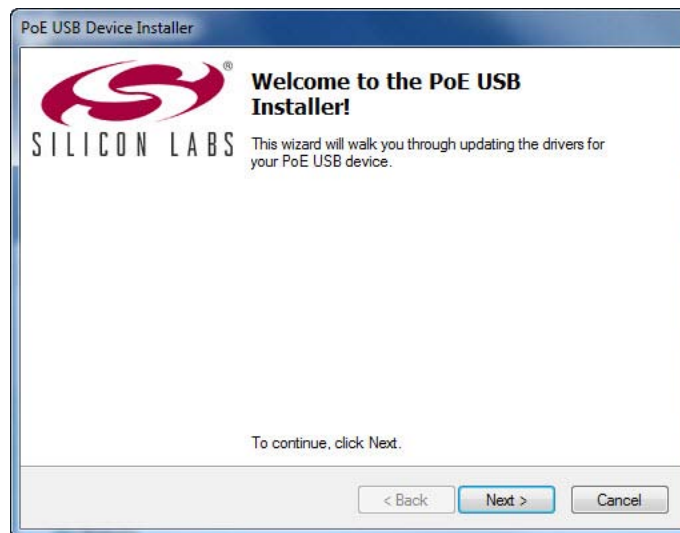

Figure 2. PoE USB Device Installer Screen

After the PoEUSB device driver is installed, then complete the installation by connecting the PoEUSB adapter card to the PC with a USB cable.

Si3452MS8-KIT

3.2. Installing the Si3452 Monitor

If you have previously installed the Si3452 Monitor, uninstall the previous version before installing the new version. To uninstall the previous version, select "Programs and Features" or "Add or Remove Programs" from the Control Panel, and then uninstall "Si3452 Monitor".

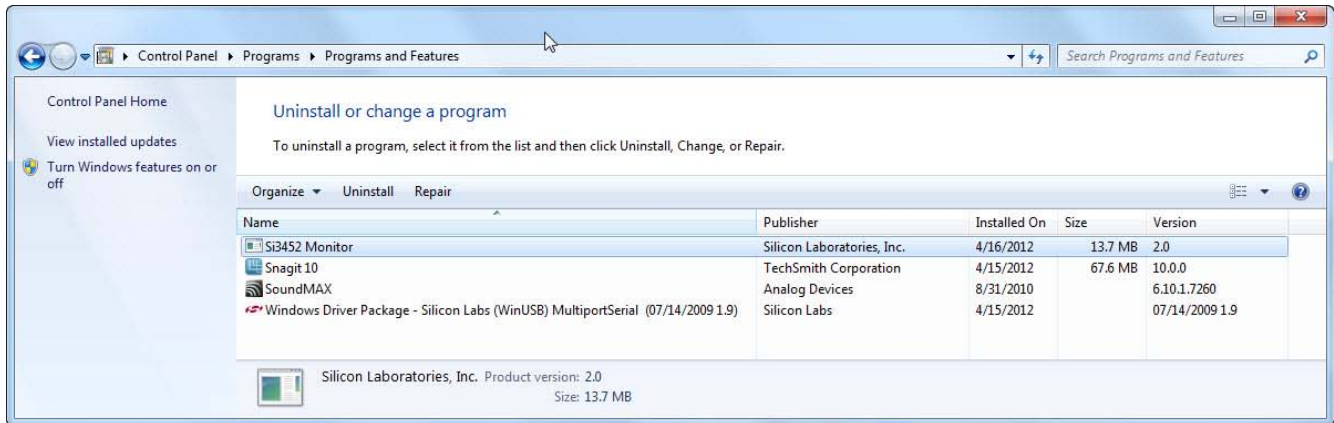

Figure 3. Uninstall Previous Rev Si3452 Monitor

To install the Si3452 Monitor, run Si3452MonitorSetup_v2.0.exe.



Figure 4. Monitor Setup Wizard

4. Hardware Installation

Figure 5 shows how all the hardware pieces of the Si3452 evaluation board fit together.

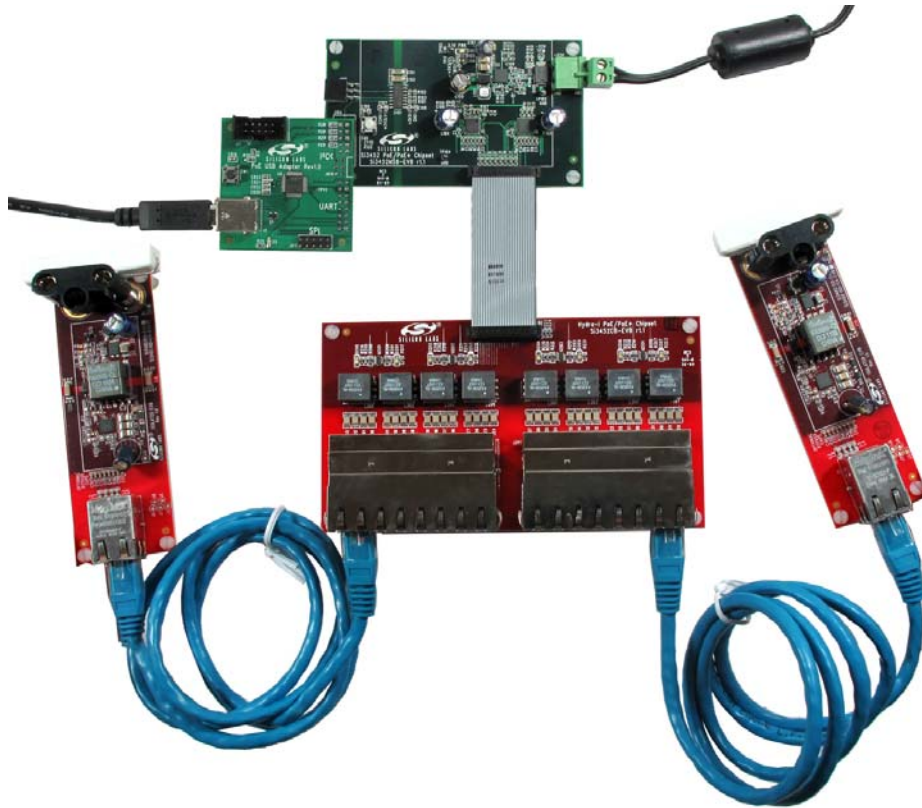

Figure 5. Evaluation Board Hardware

Si3452MS8-KIT

Perform the following steps:

1. Connect the Si3452 evaluation card (Si3452MB8-EVB) to the RJ45 (Si3452C3-EVB) card using the 24-pin ribbon cable.
2. Plug J104 of the PoEUSB adapter into J104 of the Si3452 evaluation card.
3. The high-voltage power supply should be connected to the evaluation system before it is plugged into the ac mains. Hot insertion of the high voltage is not recommended. Be careful about the polarity of the high-voltage power supply. After the high voltage supply is turned on, the power LED D101 will glow, indicating that the 3.3 V supply is active.

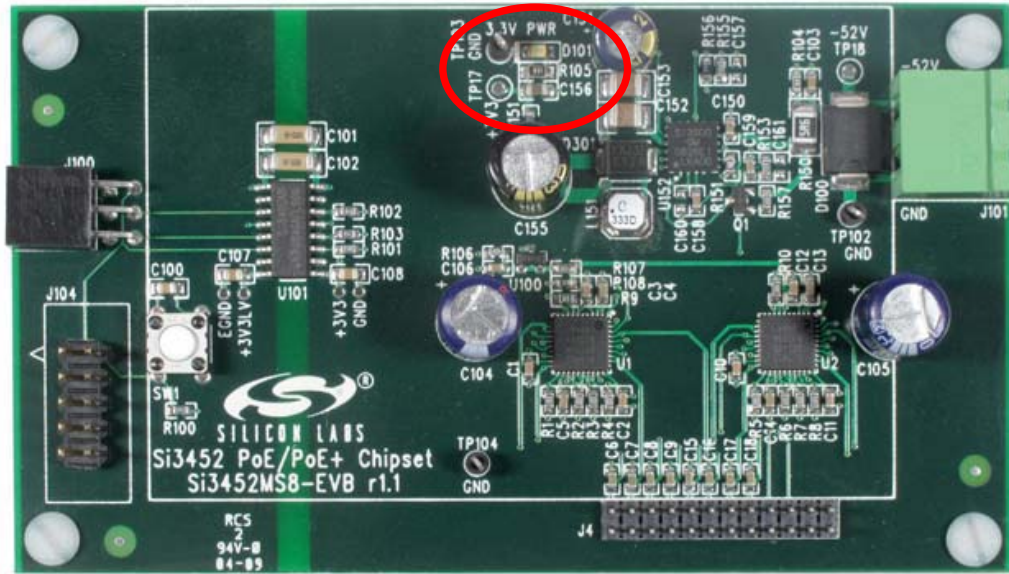

Figure 6. Location of D101 which Indicated Power Has Been Properly Applied

4. Plug the PoEUSB adapter into the computer USB cable if this was not already done during the software installation step. Connect the USB side before connecting the PoEUSB side. If the drivers were installed properly, the PC should recognize the adapter.
5. Plug in powered devices. The evaluation board is configured as a midspan power injector. The data input lines are on the top row, and the power plus data output lines are on the bottom row.

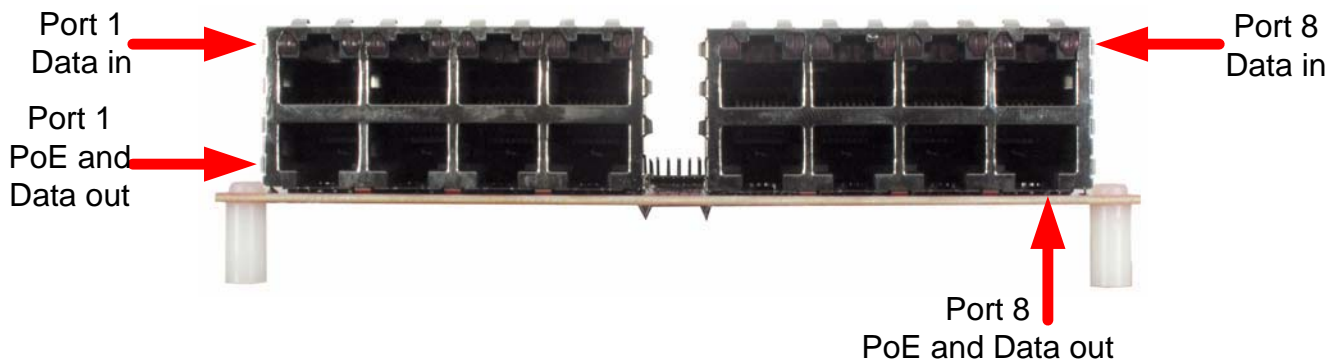

Figure 7. Connector Board Configuration

6. Start the Si3452 Monitor.

5. Using the Si3452 Monitor

To run the Si3452 Monitor, double click on the "Si3452 Monitor" desktop icon. You may also run the Si3452 Monitor from the Start menu, by selecting: Start → All Programs → Silicon Laboratories → Si3452 Monitor.

The Si3452 Monitor initially displays the basic graphical user interface (GUI), but it can be switched to the advanced GUI by clicking on the "Advanced GUI" button.

5.1. Basic GUI

The basic GUI provides high level status, configuration, and control of Si3452 port controllers.

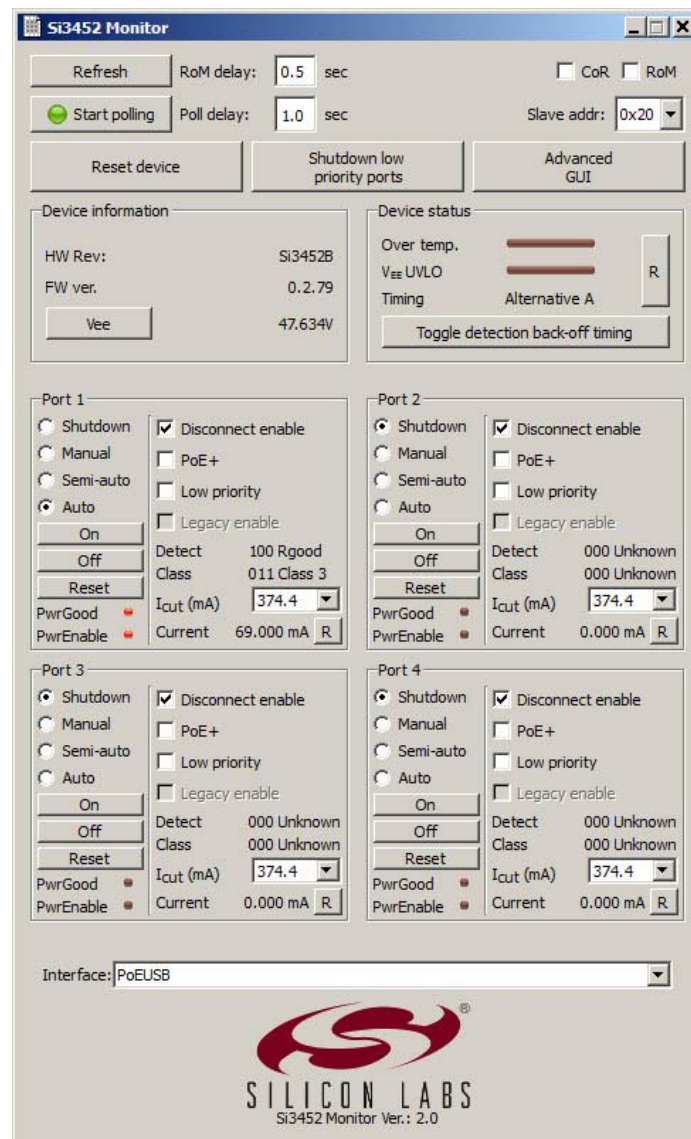

Figure 8. Basic GUI

The basic GUI contains the following:

- Monitor Control
- Interface Selector
- Device Information
- Device Status
- Port Boxes

Si3452MS8-KIT

5.1.1. Monitor Control

The primary purpose of the Monitor Control area is to configure and control the operation of the GUI itself.

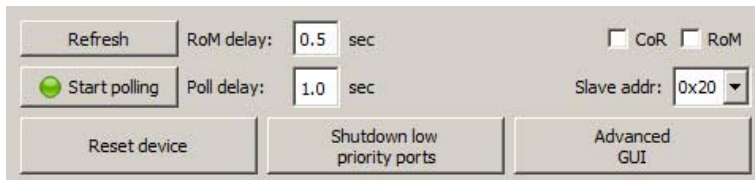

Figure 9. Monitor Control Area

The user may manually update the GUI by clicking the “Refresh” button. The GUI reads the Si3452 registers and updates the displayed information.

The user may cause the GUI to automatically update itself at regular intervals by clicking on the “Start polling” button. The green LED flashes red each time an update occurs. The “Poll delay” text box allows the user to specify the time between updates. The user may stop automatic updates by clicking on the “Stop polling” button.

The user selects which Si3452 controller to use with the “Slave addr” box. Several Si3452 controllers may be connected to the I²C bus, and each controller has a unique I²C slave address. The “Slave addr” box specifies which of the Si3452 controllers to communicate with. The GUI works with only one Si3452 at a time, but the user may dynamically switch the GUI between several Si3452s with the “Slave addr” box.

If the user checks the “CoR” (Clear on Read) check box, then the GUI reads the Si3452's CoR registers when updating. If the CoR check box is not checked, then the GUI does not read the CoR registers when updating. The CoR registers are the Port Event registers and the Device Status register. Reading a CoR register has side effects. Reading a Port Event register clears that register and clears a port event bit in the interrupt register. Reading the Device Status register clears a device event bit in the interrupt register. Consequently, if the CoR check box is checked while the GUI is polling, then events could come and go without being noticed by the user.

If the user checks the “RoM” (Read on Modify) check box, then the GUI automatically updates itself after the user modifies the GUI. The GUI automatically shows the effect of any change within a time delay, specified by the “RoM delay” text box. The RoM behavior is only useful if polling is stopped.

The Monitor Control area has three buttons. The “Reset Device” button resets the Si3452 by writing the “reset chip” command to the command register. The “Shutdown low priority ports” button turns off all low priority ports by writing the “shutdown all low priority ports” command to the command register. The “Advanced GUI” button displays the advanced GUI controls.

5.1.2. Interface Selector

The Interface Selector specifies which USB-to-I2C device to use for communicating with the Si3452 port controllers.



Figure 10. Interface Selector

The Si3452 Monitor supports several different USB-to-I²C devices. If more than one of these devices is connected to the PC at the same time, then the user can select which one to use with the Interface drop-down box.

The “Dummy” device is a substitute device that does not actually perform I²C communications. The Dummy device allows the Si3452 Monitor to open even if there are no USB-to-I²C devices connected to the PC.

The version of the Si3452 Monitor is displayed at the bottom of the window.

5.1.3. Device Information

The Device Information box displays high level information about the Si3452 device.

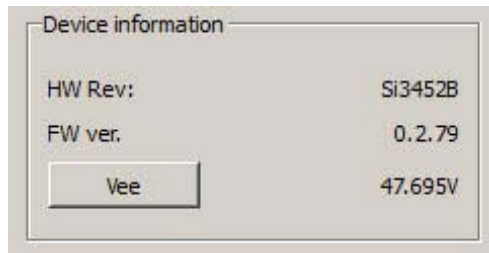

Figure 11. Device Information Box

This box displays the hardware revision of the silicon, the firmware version, and the measured Vee voltage. The user can update the Vee voltage by clicking on the “Vee” button.

5.1.4. Device Status

The Device Status box displays the high level status of the Si3452 device.

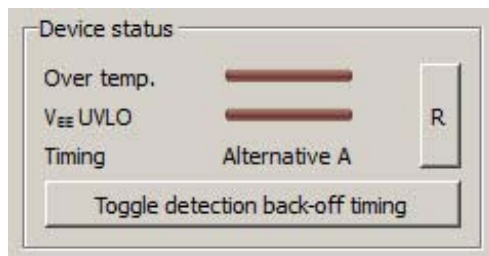

Figure 12. Device Status Box

This box displays the contents of the Device Status register. If the temperature of the Si3452 controller is too high, then the “Over temp” LED bar is bright red instead of dark red. If the Vee voltage is too low, then the “Vee UVLO” LED bar is bright red instead of dark red. This box also displays the setting of the detection back-off timing (Alternative A or Alternative B).

The user may manually update this box by clicking on the “R” (read) button. The GUI reads the Device Status register and updates the status information displayed in this box. This box is not updated by polling or by the “Refresh” button unless the CoR check box is checked.

If a device event bit is set in the interrupt register, then the “R” button is red. This indicates that the displayed device status is stale and that the Device Status register should be read. Reading the Device Status register has the side effect of clearing the device event bits in the interrupt register, consequently making the “R” button no longer red.

The “Toggle detection back-off timing” button switches the detection back-off timing between Alternative A and Alternative B. This change may not automatically be displayed in this box. The user may have to click on the “R” button to see the new timing setting. If the Device Status register has never been read, then this box displays “Alternative?” because the timing is not known.

Si3452MS8-KIT

5.1.5. Port Boxes

The port boxes display port status and have controls for configuring and controlling the ports.

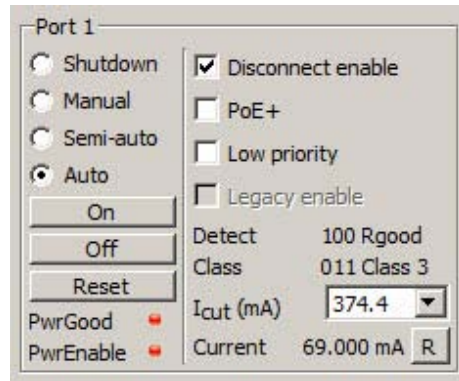

Figure 13. Port Box

5.1.5.1. Port Status

A port box displays the results of the last detection and last classification in the middle of the right pane. The PwrEnable LED (bottom left) is bright red if the port is turned on. The PwrGood LED is bright red if the measured port voltage is good.

The amount of current drawn from the port is displayed at the bottom right corner of the port box. The user may manually update the port current reading by clicking on the “R” (read) button.

5.1.5.2. Port Configuration

A port box contains four radio buttons to configure the mode of the port. The port mode may be Shutdown, Manual, Semi-auto, or Auto.

The port features can be configured with the four checkboxes on the right pane. If “Disconnect enable” is checked, the port removes power if the powered device is unplugged. If “PoE+” is checked, then the port supplies high power to a powered device that follows to the PoE+ protocol. If “Low priority” is checked, the port immediately removes power if the “Shutdown low priority ports” button is clicked. If “Legacy enable” is checked, then the port supplies power to a legacy powered device even though the powered device does not provide a valid detection resistance. The “Legacy enable” check box is disabled if the Si3452 controller does not support this feature.

The user may configure a port's Icut level with the “Icut (mA)” drop-down box. The port automatically removes power if the port current is greater than the Icut level for more than 60 milliseconds.

5.1.5.3. Port Control

A port box contains three buttons for controlling a port. The “On” button forces a port to supply power; the “Off” button forces a port to remove power, and the “Reset” button resets a port.

5.2. Advanced GUI

The advanced GUI adds additional controls to the basic GUI for low level status, configuration, and control of Si3452 controllers.

The screenshot displays the Si3452 Monitor GUI with the following sections:

- Refresh and Polling:** Refresh button, RoM delay: 0.5 sec, CoR and RoM checkboxes, Start polling button, Poll delay: 1.0 sec, Slave addr: 0x20.
- Device Information:** HW Rev: Si3452B, FW ver: 0.2.79, Vee: 47.634V.
- Device Status:** Over temp., V_{EE} UVLO, Timing: Alternative A, Toggle detection back-off timing button.
- Port 1-4 Configurations:** Each port has settings for Shutdown, Manual, Semi-auto, Auto, Detect, Class, I_{cut} (mA), PwrGood, and PwrEnable.
- Interrupt Enable:** Checkboxes for Power enable event, Power good event, Disconnect event, Detect completed, Class completed, Port current overload, Startup overload, and Device status.
- Events:** Interrupt line active indicator, Item (Read CoR) buttons (P1, P2, P3, P4), and event status indicators for Power enable change, Power good change, Disconnect, Detect complete, Class complete, Port current overload, and Startup overload.
- Register List:**

Register	Type	Value (Bin)	Value	R	W
Registers					
Interrupt					
<input checked="" type="checkbox"/> 00 - Interrupt	RO	0000 0001	0x01	R	W
<input checked="" type="checkbox"/> 01 - IntMask	RW	1000 0101	0x85	R	W
Event					
<input checked="" type="checkbox"/> 02 - Port 1 Events	CR	XXXX XXXX		R	W
<input checked="" type="checkbox"/> 03 - Port 2 Events	CR	XXXX XXXX		R	W
<input checked="" type="checkbox"/> 04 - Port 3 Events	CR	XXXX XXXX		R	W
<input checked="" type="checkbox"/> 05 - Port 4 Events	CR	XXXX XXXX		R	W
Status					
<input checked="" type="checkbox"/> 06 - Port 1 Status	RO	1101 1100	0xdc	R	W
<input checked="" type="checkbox"/> 07 - Port 2 Status	RO	0000 0000	0x00	R	W
<input checked="" type="checkbox"/> 08 - Port 3 Status	RO	0000 0000	0x00	R	W
<input checked="" type="checkbox"/> 09 - Port 4 Status	RO	0000 0000	0x00	R	W
Configuration					
<input checked="" type="checkbox"/> 0a - Port 1 Config	RW	0000 0111	0x07	R	W
<input checked="" type="checkbox"/> 0b - Port 2 Config	RW	0000 0100	0x04	R	W
<input checked="" type="checkbox"/> 0c - Port 3 Config	RW	0000 0100	0x04	R	W
<input checked="" type="checkbox"/> 0d - Port 4 Config	RW	0000 0100	0x04	R	W
<input checked="" type="checkbox"/> 0e - Port 1 Icut	RW	0111 0101	0x75	R	W
<input checked="" type="checkbox"/> 0f - Port 2 Icut	RW	0111 0101	0x75	R	W
<input checked="" type="checkbox"/> 10 - Port 3 Icut	RW	0111 0101	0x75	R	W
<input checked="" type="checkbox"/> 11 - Port 4 Icut	RW	0111 0101	0x75	R	W
Global Device					
<input checked="" type="checkbox"/> 12 - Command Register	WO	0001 1111	0x1f	R	W

Figure 14. Advanced GUI

The advanced GUI consists of the following sections:

- Interrupt Enable
- Events
- Register List

5.2.1. Interrupt Enable

The Interrupt Enable box specifies which events cause the Si3452 to generate an interrupt.

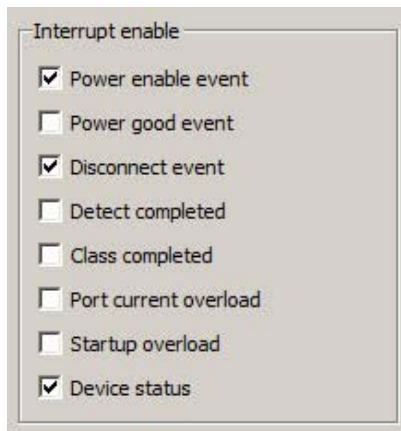

Figure 15. Interrupt Enable Box

5.2.2. Events

The Events box displays the status of the interrupt line and the port events.

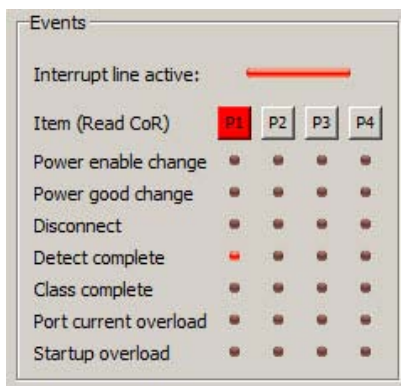

Figure 16. Events Box

If the interrupt line is active, then the LED bar at the top of the Events box is bright red instead of dark red. Note that if there are multiple Si3452 controllers in the system, one or more of these controllers may be pulling the interrupt line low. It may not be the currently-selected Si3452 that is making the interrupt line active.

The Port Events registers can be read using the port event buttons under the Interrupt line active LED bar. Further below the port event, LEDs display the status of each event for each port. If a port event is active, then the corresponding LED is bright red.

The user may manually update a port's event LEDs by clicking on the port's event button (P1, P2, P3, P4). The GUI reads the corresponding Port Events register and updates the port's event LEDs. Port event LEDs are not updated by polling or by the "Refresh" button unless the CoR check box is checked.

If a port event bit is set in the interrupt register, then the corresponding port event button (P1, P2, P3, P4) is red. This indicates that the port's event LEDs are stale and that the Port Events register should be read. Reading a Port Events register has the side effect of clearing that Port Events register and clearing the port event bit in the interrupt register, consequently making the port event button no longer red.

5.2.3. Register List

The Register List displays the contents of the Si3452 registers and allows the user to change the register contents.

Register	Type	Value (Bin)	Value	R	W
<input checked="" type="checkbox"/> Registers					
<input checked="" type="checkbox"/> Interrupt					
<input checked="" type="checkbox"/> 00 - Interrupt	RO	0000 0001	0x01	R	W
<input checked="" type="checkbox"/> 01 - IntMask	RW	1000 0101	0x85	R	W
<input checked="" type="checkbox"/> Event					
<input checked="" type="checkbox"/> 02 - Port 1 Events	CR	0000 1000	0x08	R	W
<input checked="" type="checkbox"/> 03 - Port 2 Events	CR	XXXX XXXX		R	W
<input checked="" type="checkbox"/> 04 - Port 3 Events	CR	XXXX XXXX		R	W
<input checked="" type="checkbox"/> 05 - Port 4 Events	CR	XXXX XXXX		R	W
<input checked="" type="checkbox"/> Status					
<input checked="" type="checkbox"/> 06 - Port 1 Status	RO	1101 1100	0xdc	R	W
<input checked="" type="checkbox"/> 07 - Port 2 Status	RO	0000 0000	0x00	R	W
<input checked="" type="checkbox"/> 08 - Port 3 Status	RO	0000 0000	0x00	R	W
<input checked="" type="checkbox"/> 09 - Port 4 Status	RO	0000 0000	0x00	R	W
<input checked="" type="checkbox"/> Configuration					
<input checked="" type="checkbox"/> 0a - Port 1 Config	RW	0000 0111	0x07	R	W
<input checked="" type="checkbox"/> 0b - Port 2 Config	RW	0000 0100	0x04	R	W
<input checked="" type="checkbox"/> 0c - Port 3 Config	RW	0000 0100	0x04	R	W
<input checked="" type="checkbox"/> 0d - Port 4 Config	RW	0000 0100	0x04	R	W
<input checked="" type="checkbox"/> 0e - Port 1 Icut	RW	0111 0101	0x75	R	W
<input checked="" type="checkbox"/> 0f - Port 2 Icut	RW	0111 0101	0x75	R	W
<input checked="" type="checkbox"/> 10 - Port 3 Icut	RW	0111 0101	0x75	R	W
<input checked="" type="checkbox"/> 11 - Port 4 Icut	RW	0111 0101	0x75	R	W
<input checked="" type="checkbox"/> Global Device					
<input checked="" type="checkbox"/> 12 - Command Register	WO	0001 1111	0x1f	R	W

Figure 17. Register List

The Register List displays all of the Si3452's registers grouped by category. Each category of registers can be expanded and collapsed by clicking on the plus and minus signs at the left edge of the Register List.

The Register List displays the type of each register. Each register is either RW (read/write), RO (read only), WO (write only) or CR (Clear on Read). WO registers reflect the value applied by the user.

The user may specify which registers to read (when the GUI is updated) by checking a box at the left of each register name. Refreshing, polling, and RoM, all depend on these settings. Clear on Read registers are read only if both the CoR check box is checked and the check box for the individual CR register is checked.

The user may read and write individual registers by using the "R" (read) and "W" (write) buttons at the right edge of each register. The "R" and "W" buttons are disabled if the operation is not allowed for the type of register. The whole register file can be updated at once by clicking on the "Refresh" button.

The Register List displays the value of each register in binary and hexadecimal form. If a register has not yet been read, then its binary value is displayed as all Xs, and its hexadecimal value is blank.

A register's hexadecimal value is displayed in a text box. If a register is not writable (RO or CR), then its text box is gray and its hexadecimal value cannot be changed by the user. If a register is writable (RW), then its text box is white and its hexadecimal value can be changed by the user. The accepted format in text boxes are: octal (0 nnn). After changing a register's value, the user clicks on the register's "W" button to write the new value to the register.

6. Operating the System

The RJ45 connector board has eight LEDs for the eight ports. The LEDs are driven by a comparator circuit with a threshold of about 2 V. When the ports are in auto mode, the LEDs in the RJ45 connector board flash, indicating the detection cycle until a valid PD is connected. Once a valid PD is connected and the port is turned on, the LEDs will glow steadily until the PD is disconnected. Once the PD is connected, the port current will be displayed on the GUI.

The easiest way to get started is to put all of the ports in Auto mode. In Auto mode, detection, classification, power management based on classification (Icut setting), disconnect (when enabled by “Dis Enable”), fault protection, fault recovery, and port monitoring all happen without user intervention.

If the GUI is left in polling mode, the port status, port current, Vee voltage are all automatically updated by polling the appropriate registers of the Si3452.

The Si3452 itself normally powers up as Alternative A, which means there is no detection back-off. This is the most common usage for the Si3452. The RJ-45 connector board for the evaluation kit is configured to inject the power on the “spare pairs” of the Ethernet cable, which is the Alternative B or “Midspan” connection. Detection back-off is helpful for insuring that a midspan and an endpoint do not compete with each other and result in a failure to provide power. With detection back-off, the time between detection pulses is increased to just over two seconds so as not to compete with the normal (approximately three times per second) detection of an endpoint. If detection back-off is required, click the “Midspan” button to toggle this mode. You will see that the LEDs on the connector board now flash at the slower detection speed. To toggle the mode back to standard detection timing, click the button again.

The Si3452 in auto mode is fully-compliant with the 802.3at standard (often called PoE+), which allows up to 30 W to be delivered over the Ethernet cable. To enable the higher power support for a given port, click the “PoE+” check box for that port.

In PoE+ power mode, the Si3452 automatically performs the two-event classification and increases the cut-off current if a class 4 PD is detected. The Si3401 evaluation board provided with the kit is configured to provide the Class 4 signature; so, if the PoE+ mode is enabled and the Si3401 PD is plugged in, the cut-off current is automatically set to 643.2 mA. The screen shot in Figure 18 shows the result of plugging in a class 4 PD (into Port1) with PoE+ power enabled.

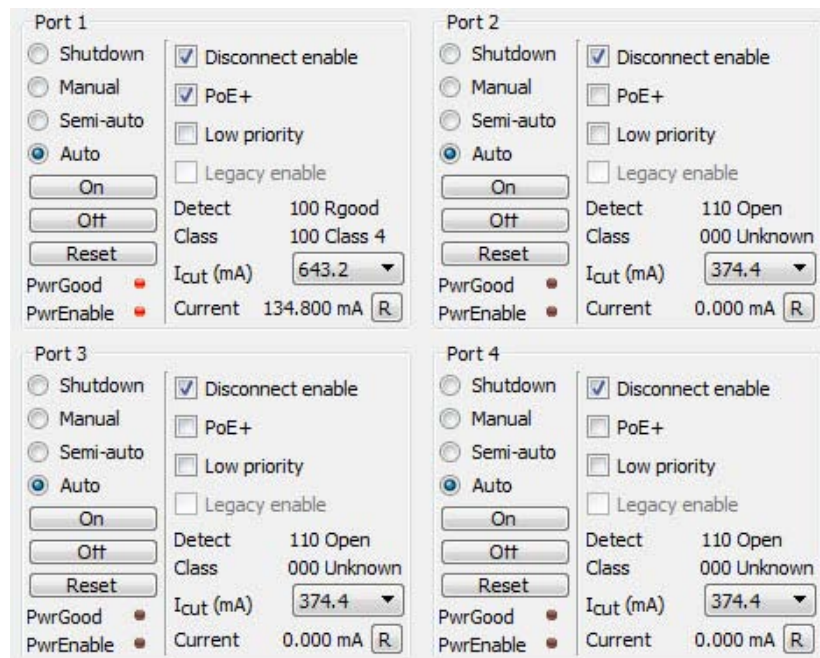

Figure 18. Result of Putting Port 1 into Auto and POE+ Mode and Plugging in the Si3401 Class 4 PD with a 5 Ω Load

7. Board Schematics, BOM, and Layout

The following are general PCB layout considerations. Detailed schematics, BOM, and layout can also be found in the following sections. Visit the Silicon Labs Technical Support web page and register to submit a technical support request, particularly if you are not closely following the recommended reference design.

7.1. Design and Layout Considerations

Due to the high current of up to 800 mA per port, the following board layout guidelines apply.

The VEE1, VEE2, VEE3, and VEE4 pins can carry up to 800 mA and are connected to a VEE bus. The VEE bus for a 4-port PCB layout can thus carry as much as 3.2 A current. The best practice is to devote an entire inner layer for VEE power routing.

Similarly, GND1/2 and GND3/4 pins can carry up to 1.6 A per pin, and the GND return bus should be at least as wide as the VEE bus. The best practice is to devote an entire inner layer for ground power routing.

The ground power plane does not generally have a high frequency content (other than external faults); so, it is generally acceptable to use the ground power plane as a ground signal plane and tie AGND and GND12 and GND34 to this plane as well.

The VOUTn pins carry up to 800 mA dc and up to 5 A in faults; so, a 20 mil trace with wide or multiple vias is also recommended. The VDETn pins also carry fault current; so, this pin connection to VOUTn needs to use 20 mil traces and wide or multiple vias where needed.

The VDD currents are not large; so, it is acceptable to route the VDD nodes on one of the outer layers. If care is taken to avoid disruption of the high-current paths, VDD can be globally routed on one of the power planes and then locally routed on an inner or outer layer.

To avoid coupling between surge events and logic signals, it is recommended that VOUTn traces be routed on the side opposite the I²C interface pins.

The thermal pad of the Si3452/3 is connected to VEE. At full IEEE 802.3at and a current of 600 mA on each port, the dissipation of the Si3452/3 is up to 1.2 W; so, multiple vias are required to conduct the heat from the thermal pad to the VEE plane. As many as 36 small vias provide the best thermal conduction. Heat is dissipated through the Si3452 by vias to a large Vee plane on the back of the board. Chip-to-chip spacing should be kept to greater than one inch to reduce peak temperatures associated with the Si3452 chips from heating each other.

The I²C bus runs at a modest speed of 400 kHz maximum. The I²C bus lines should be routed away from analog lines like Rbias or Vref but can otherwise be routed with ordinary care.

For the Si3452 itself, there are no EMI considerations. The Si3500 dc-to-dc converter in the reference design is a potential EMI source; so, care must be used in routing the FET output (SWO). The lead lengths should be kept short, and SWO should be kept away from the analog nodes. Also, the area enclosed by the paths between the input filter caps to the inductor and returning to SWO and Vss and also from the output filter caps to the inductor and returning through the diode should be minimized. Following the reference design closely in this area will insure success.

Si3452MS8-KIT

7.2. Si3452 Schematics

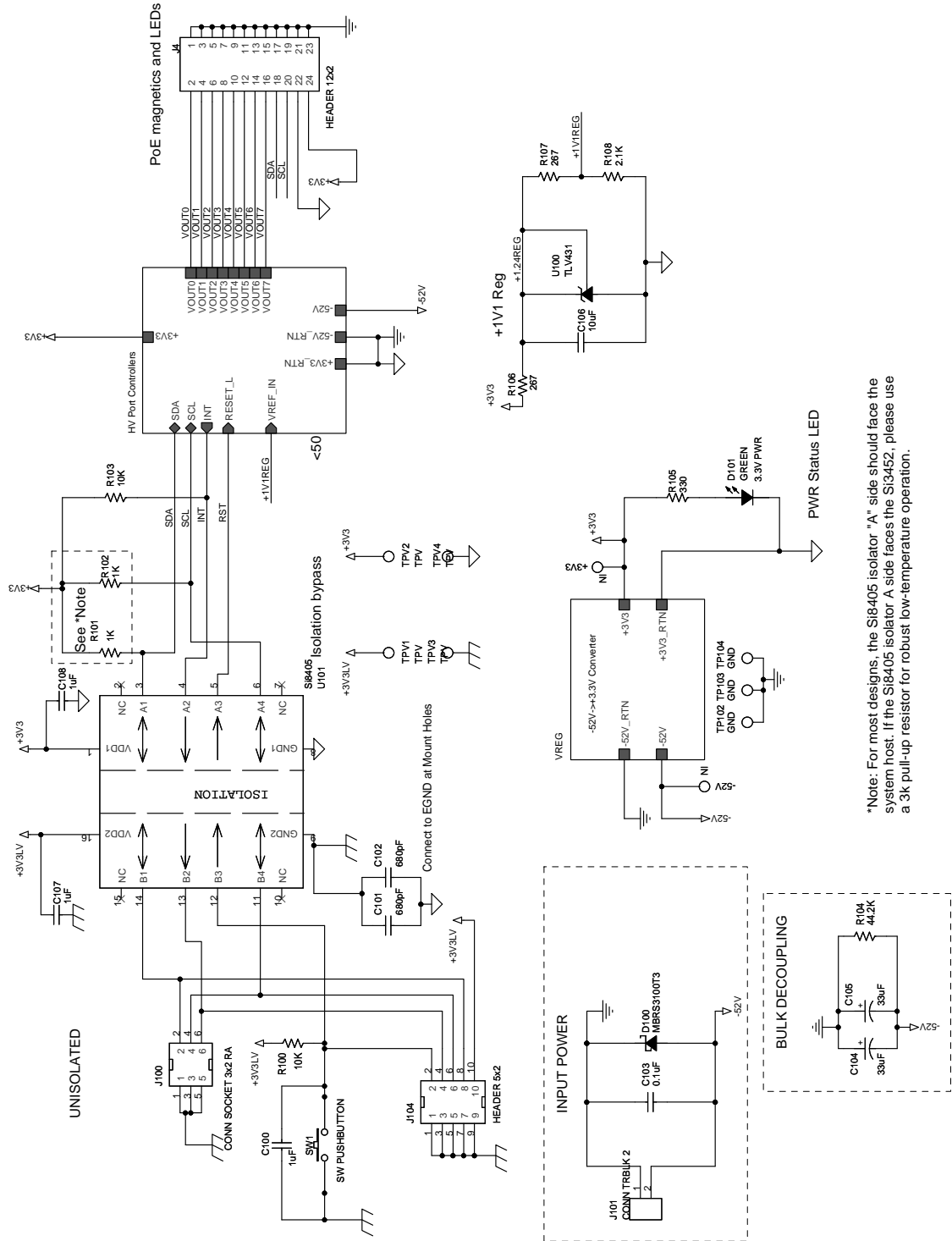

*Note: For most designs, the Si8405 isolator "A" side should face the system host. If the Si8405 isolator A side faces the Si3452, please use a 3k pull-up resistor for robust low-temperature operation.

Figure 19. Top Level

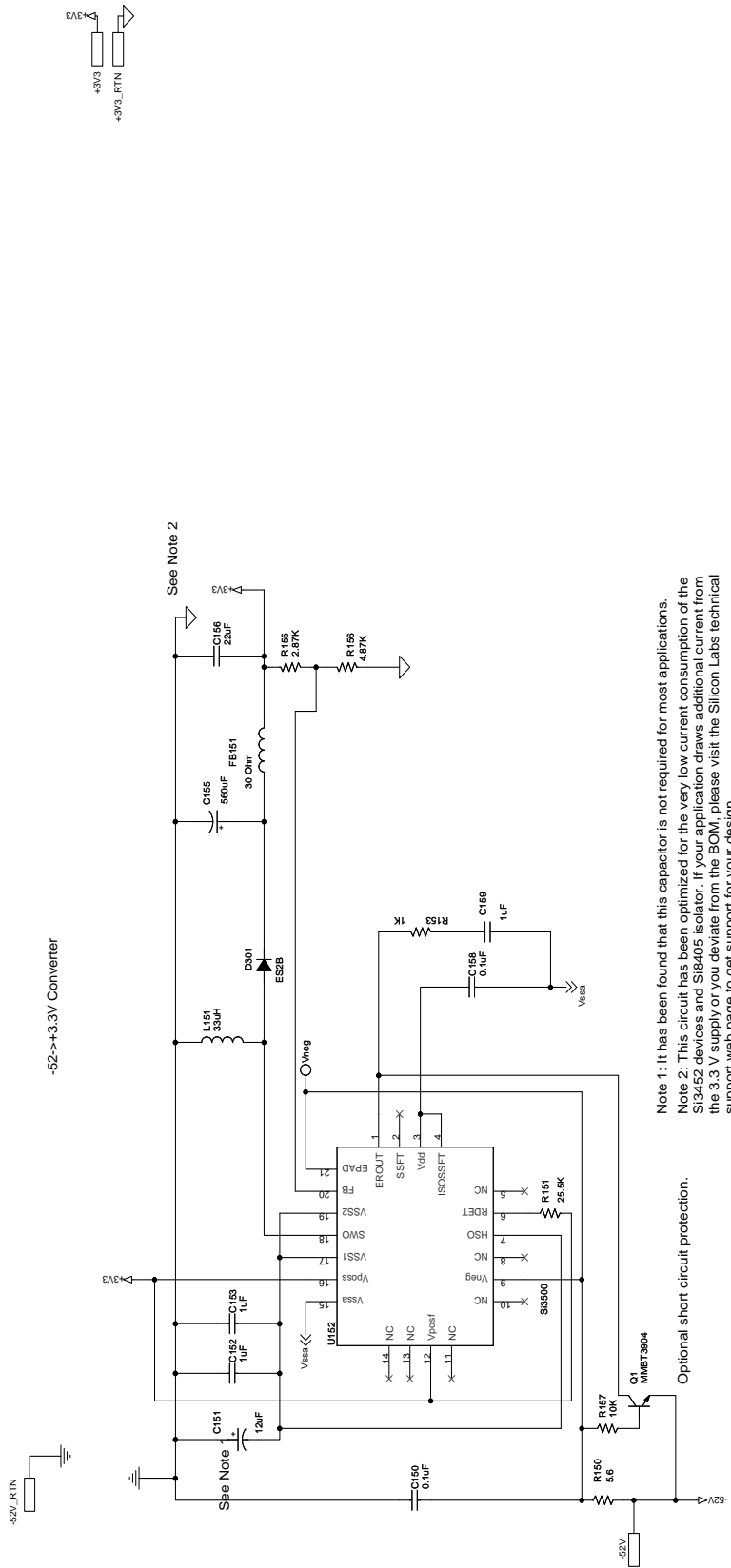

Note 1: It has been found that this capacitor is not required for most applications.
 Note 2: This circuit has been optimized for the very low current consumption of the Si3452 devices and Si8405 Isolator. If your application draws additional current from the 3.3 V supply or you deviate from the BOM, please visit the Silicon Labs technical support web page to get support for your design.

Figure 20. DC-DC Converter

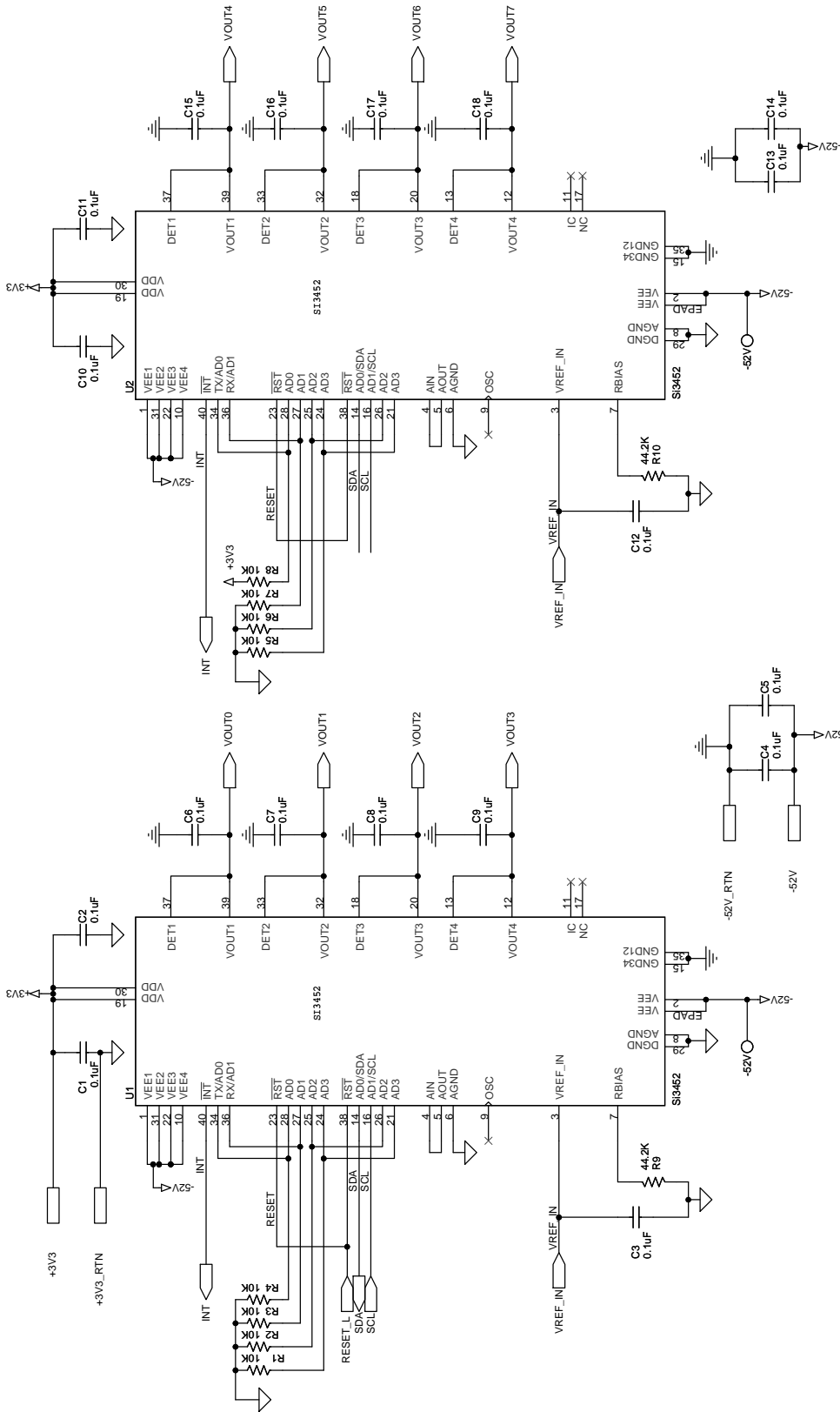

Figure 21. Si3452 Controllers

7.3. Si3452 Layout

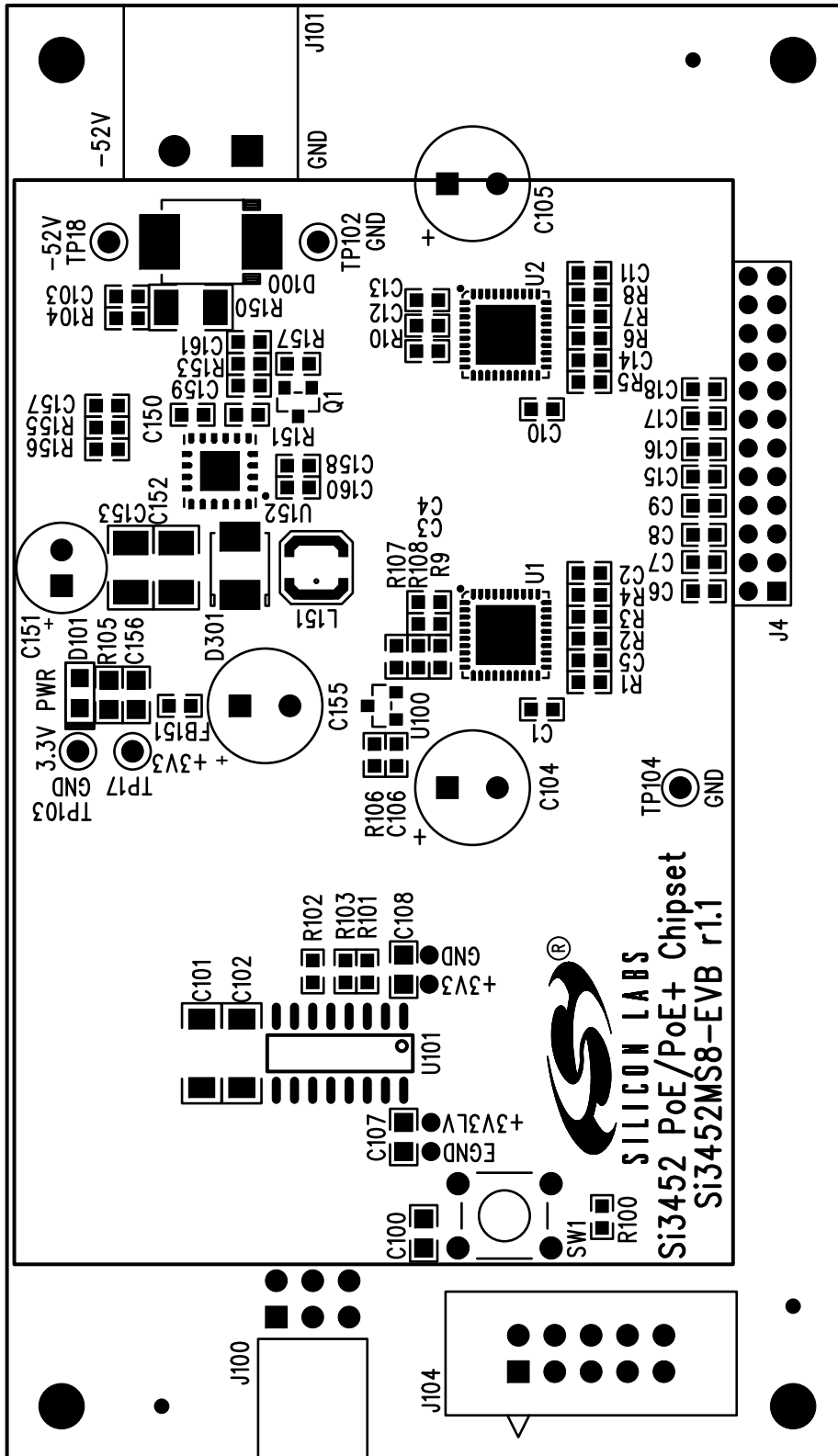

Figure 22. Si3452 Top Silkscreen

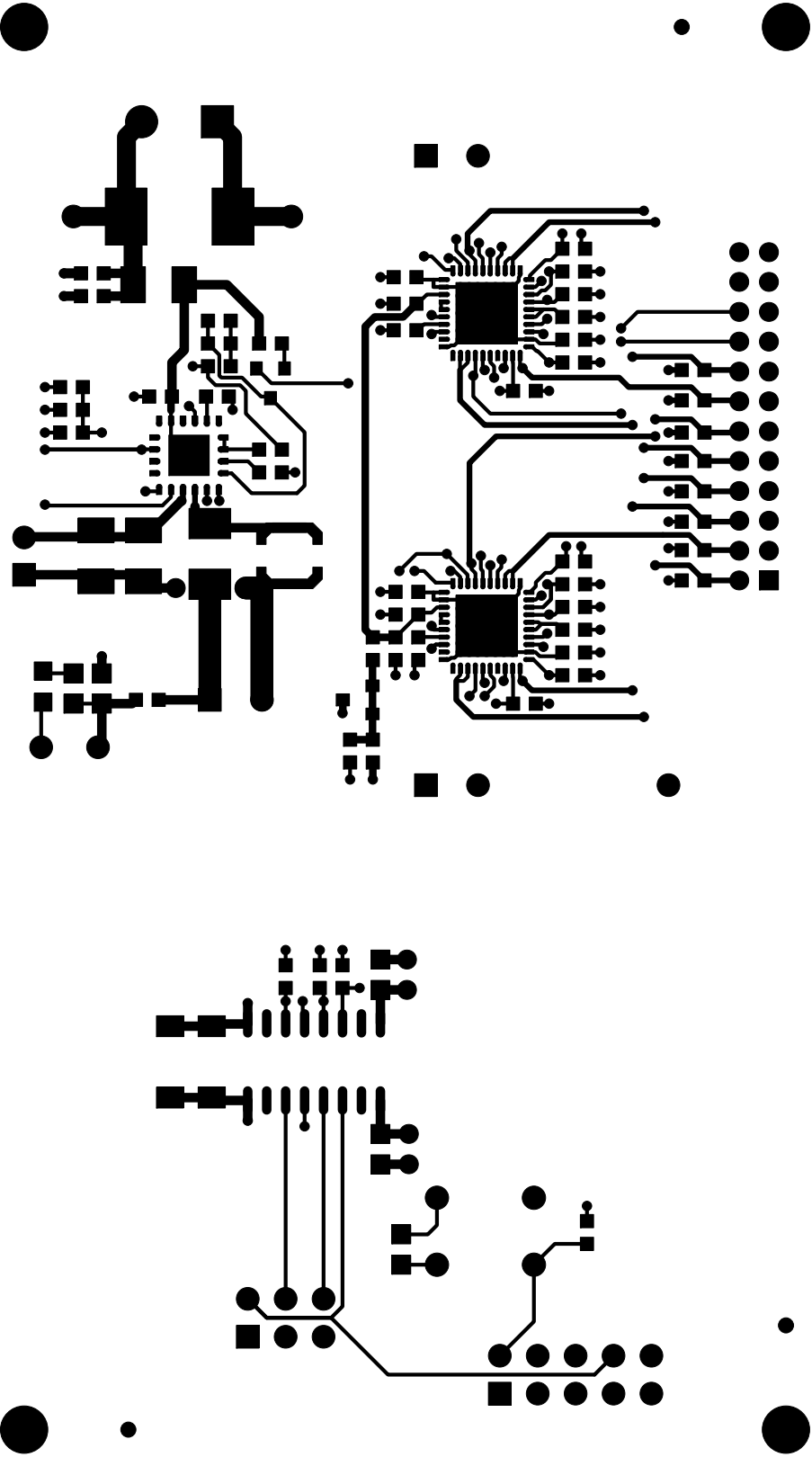

Figure 23. Si3452 Primary Side

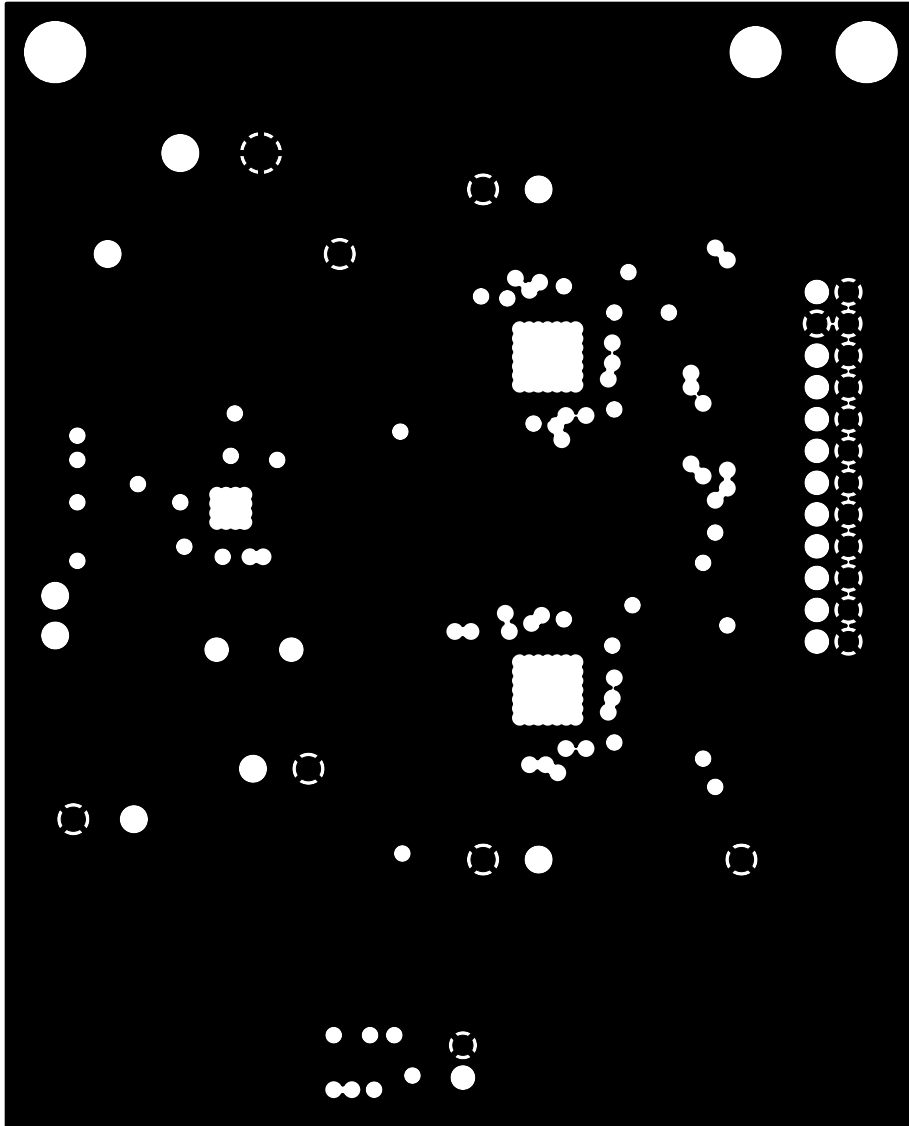
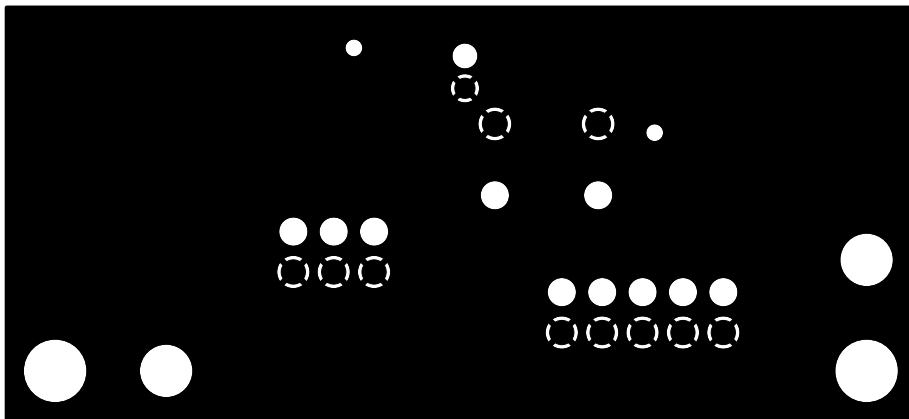

Figure 24. Si3452 Ground Plane



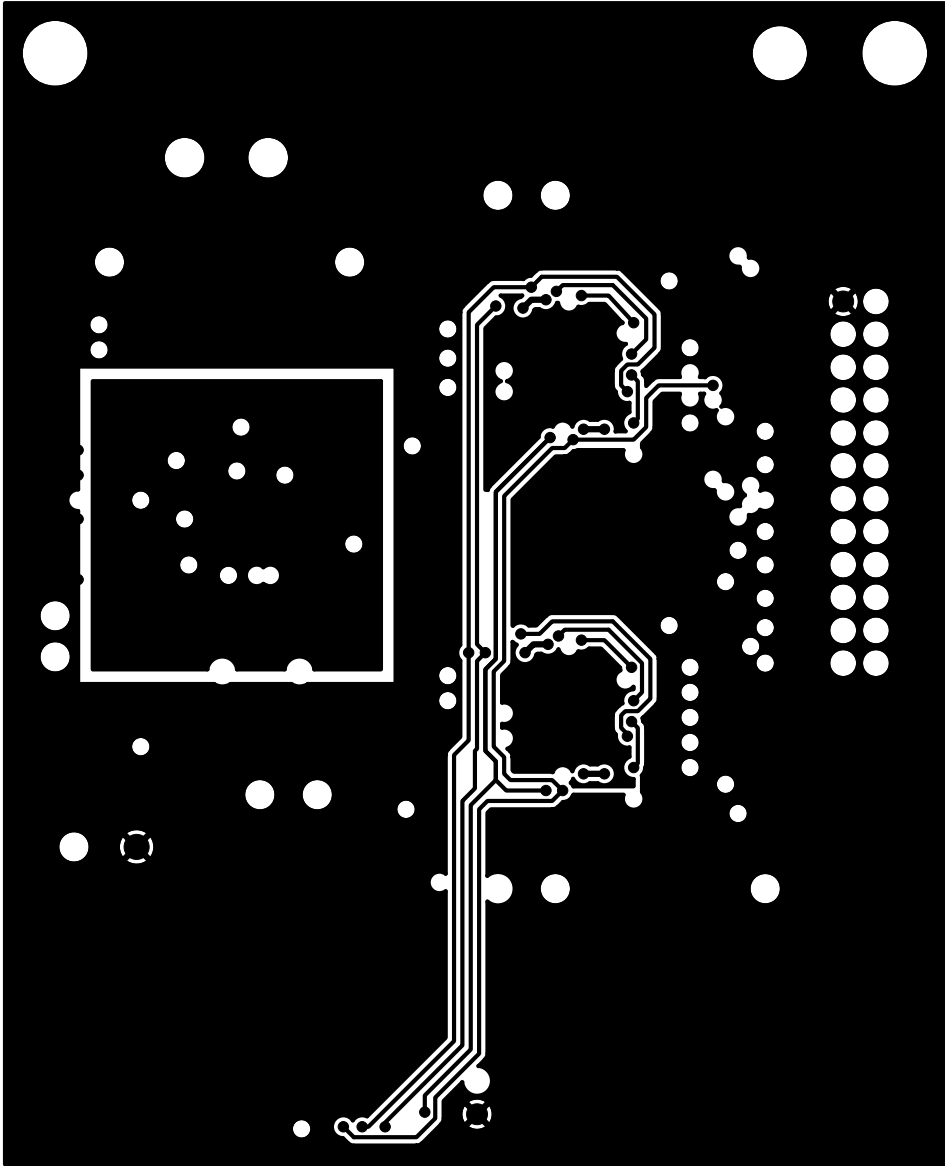
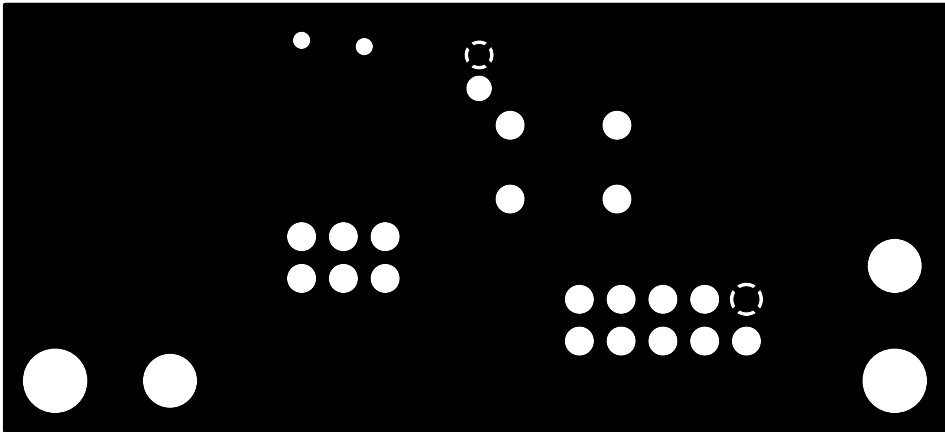

Figure 25. Si3452 Power Plane



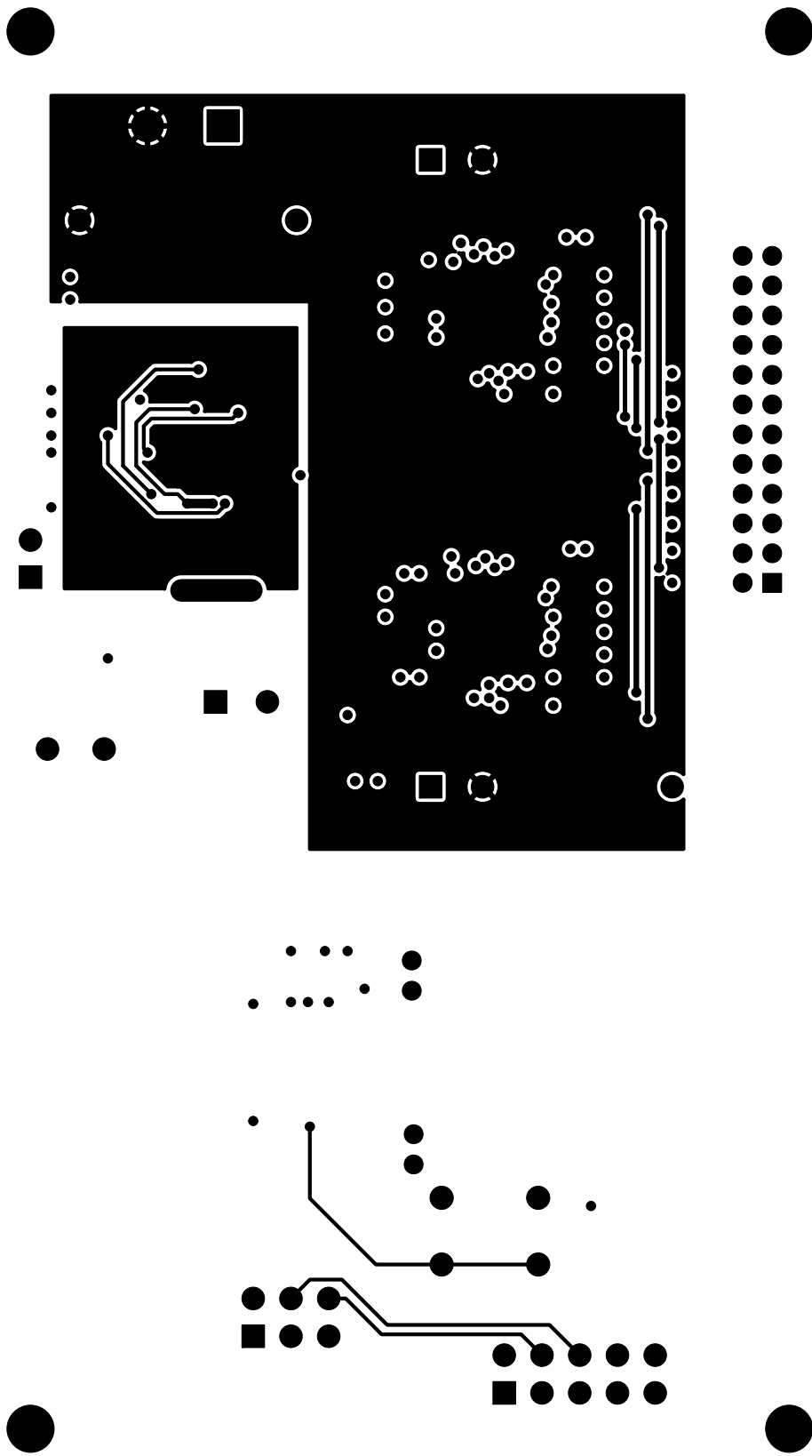

Figure 26. Si3452 Secondary Side

Si3452MS8-KIT

7.4. Si3452 Bill of Materials

Table 2. Si3452 Bill of Materials

Item	Qty	Reference	Value	Rating and Voltage	Tol	Type	PCB Footprint	Manufacturer Part Number	Manufacturer
1	6	C1,C2,C3,C10,C11,C12	0.1 μ F	16 V	\pm 20%	X7R	C0603	C0603X7R160-104M	Venkel
2	14	C4,C5,C6,C7,C8,C9,C13,C14,C15,C16,C17,C18,C103,C150	0.1 μ F	100 V	\pm 20%	X7R	C0603	C0603X7R101-104M	Venkel
3	3	C100,C017,C108	1 μ F	16 V	\pm 20%	X7R	C0805	C0805X7R160-105M	Venkel
4	2	C101,C102	680 pF	250 V	\pm 15%	Y3	C1808	GA342QR7GD681K W01L	Murata
5	2	C104,C105	33 μ F	100 V	\pm 20%	Alum Elec	C3.5X8MM-RAD	ECA2AM330	Panasonic
6	1	C106	10 μ F	6.3 V	\pm 20%	X5R	C0603	C0603X5R6R3-106M	Venkel
7	1	C151*	12 μ F	100 V	\pm 20%	Alum Elec	C2.5X6.3MM-RAD	EEUFC2A120	Panasonic
8	2	C152,C153	1 μ F	100 V	\pm 10%	X7R	C1210	C1210X7R101-105K	Venkel
9	1	C155	560 μ F	6.3 V	\pm 20%	Alum Elec	C3.5X8MM-RAD	EEUFM0J561	Panasonic
10	1	C156	22 μ F	6.3 V	\pm 20%	X5R	C0805	C0805X5R6R3-226M	Venkel
11	1	C157							
12	1	C158	0.1 μ F	25 V	\pm 10%	X7R	C0603	C0603X7R250-104K	Venkel
13	1	C159	1 μ F	10 V	\pm 10%	X7R	C0603	C0603X7R100-105K	Venkel
14	1	C160							
15	1	C161							
16	1	D100	MBRS3100T3	3 A,100 V		Schottky	DO-214AB	MBRS3100T3	On Semi
17	1	D101	Green	30 mA, 2.2 V		SMT	LED-0805-K	LTST-C170GKT	LITE_ON INC
18	1	D301	ES2B	2.0 A, 100 V		Single	DO-214AA	ES2B	Diodes Inc
19	1	FB151	BLM18PG300SN1	1000 mA		SMT	L0603	BLM18PG300SN1	MuRata
20	1	J4	HEADER 12x2			Header	CONN-2X12-2MM	TMM-112-01-T-D	Samtec
21	1	J100	CONN SOCKET 3x2 RA			Socket	CONN2X3-FRA	SSQ-103-02-G-D-RA	Samtec
22	1	J101	CONN TRBLK 2			Term Blk Male	CONN-TB-1757242	1757242	PHOENIX CONTACT

*Note: See schematic notes in Figures 19 and 20.

Table 2. Si3452 Bill of Materials (Continued)

Item	Qty	Reference	Value	Rating and Voltage	Tol	Type	PCB Footprint	Manufacturer Part Number	Manufacturer
23	1	J104	HEADER 5x2			Header	CONN2X5-4W	TSW-105-07-T-D	Samtec
24	1	L151	33 μ H	0.4 A	$\pm 20\%$	Shielded	IND-4018	LPS4018-333	Coilcraft
25	1	Q1	MMBT3904	200 mA, 40 V		NPN	SOT23-BEC	MMBT3904	Fairchild
26	9	R1,R2,R3,R4, R5,R6,R7,R8, R157	10 k Ω	1/10 W	$\pm 5\%$	Thick-Film	R0603	CR0603-10W-103J	Venkel
27	3	R9,R10,R104	44.2 k Ω	1/10 W	$\pm 1\%$	Thick-Film	R0603	CR0603-10W-4422F	Venkel
28	2	R100,R103	10 k Ω	1/10 W	$\pm 1\%$	Thick-Film	R0603	CR0603-10W-1002F	Venkel
29	3	R101,R102, R153*	1 k Ω	1/10 W	$\pm 1\%$	Thick-Film	R0603	CR0603-10W-1001F	Venkel
30	1	R105	330 Ω	1/10 W	$\pm 1\%$	Thick-Film	R0805	CR0805-10W-3300F	Venkel
31	2	R106,R107	267 Ω	1/10 W	$\pm 1\%$	Thick-Film	R0603	CR0603-10W-2670F	Venkel
32	1	R108	2.1 k Ω	1/16 W	$\pm 1\%$	Thick-Film	R0603	CR0603-16W-2101F	Venkel
33	1	R150	5.6 Ω	1/4 W	$\pm 5\%$	Thick-Film	R1210	CR1210-4W-5R6J	Venkel
34	1	R151	25.5 k Ω	1/16 W	$\pm 1\%$	Thick-Film	R0603	CR0603-16W-2552F	Venkel
36	1	R155	2.87 k Ω	1/16 W	$\pm 1\%$	Thick-Film	R0603	CR0603-16W-2871F	Venkel
37	1	R156	4.87 k Ω	1/16 W	$\pm 1\%$	Thick-Film	R0603	CR0603-16W-4871F	Venkel
38	1	SW1	SW PUSHBUT-TON	50 mA, 12 Vdc			SW-PB-MOM	101-0161-EV	Mountain Switch
40	1	TP17	Test Point			Red	TESTPOINT	151-207	Kobiconn
41	1	TP18	Test Point			White	TESTPOINT	151-201	Kobiconn
42	3	TP102,TP103, TP104	Test Point			Black	TESTPOINT	151-230	Kobiconn
43	2	U1,U2	Si3452	-70 V		POE	QFN40N6X6P0.5	Si3452	SiLabs
44	1	U100	TLV431	7 V		SHUNT	TLV431-DBZ	TLV431BCDBZR	TI
45	1	U101	Si8405	2500 V _{RMS}		Isolator	SO16N6.0P1.27	Si8405	SiLabs
46	1	U152	Si3500	-70 V		DC-DC	QFN20N5X5P0.8	Si3500	SiLabs

*Note: See schematic notes in Figures 19 and 20.

Si3452MS8-KIT

7.5. RJ45 Connector Board Schematics

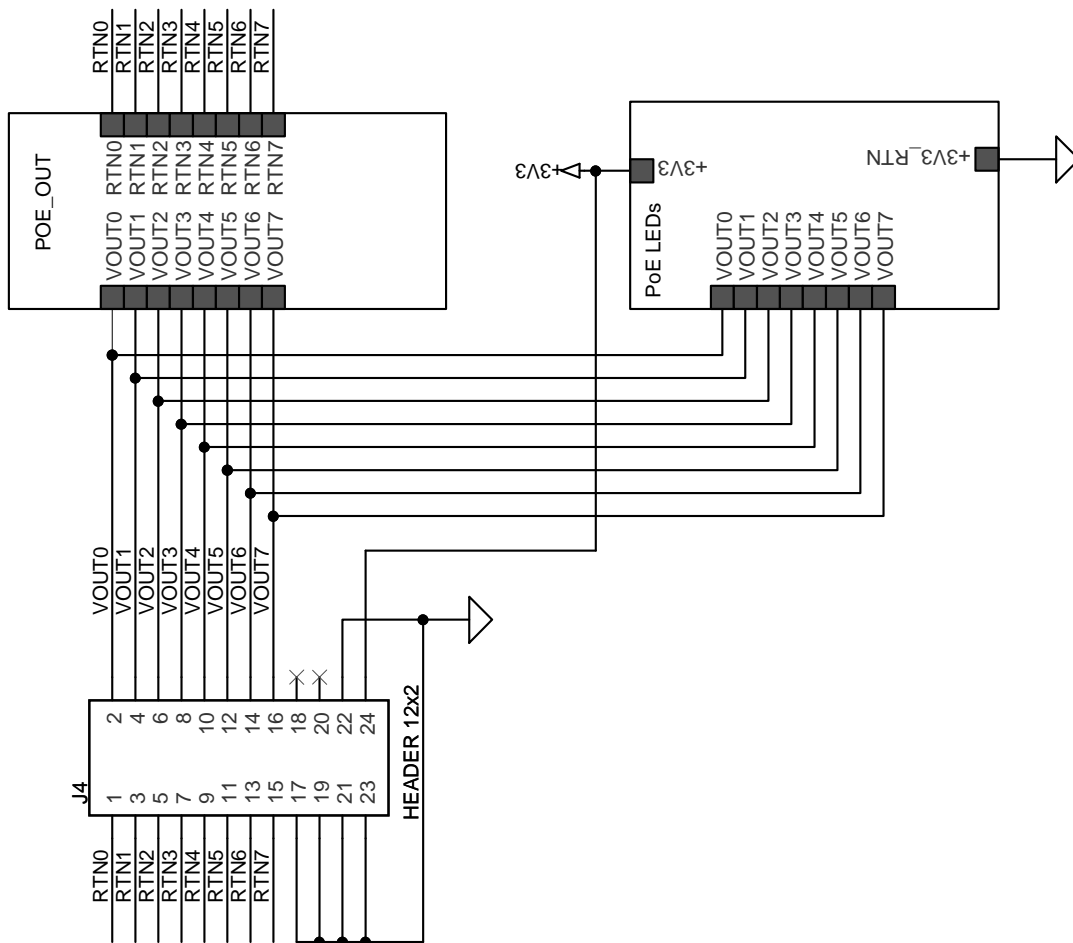

Figure 27. Top Level

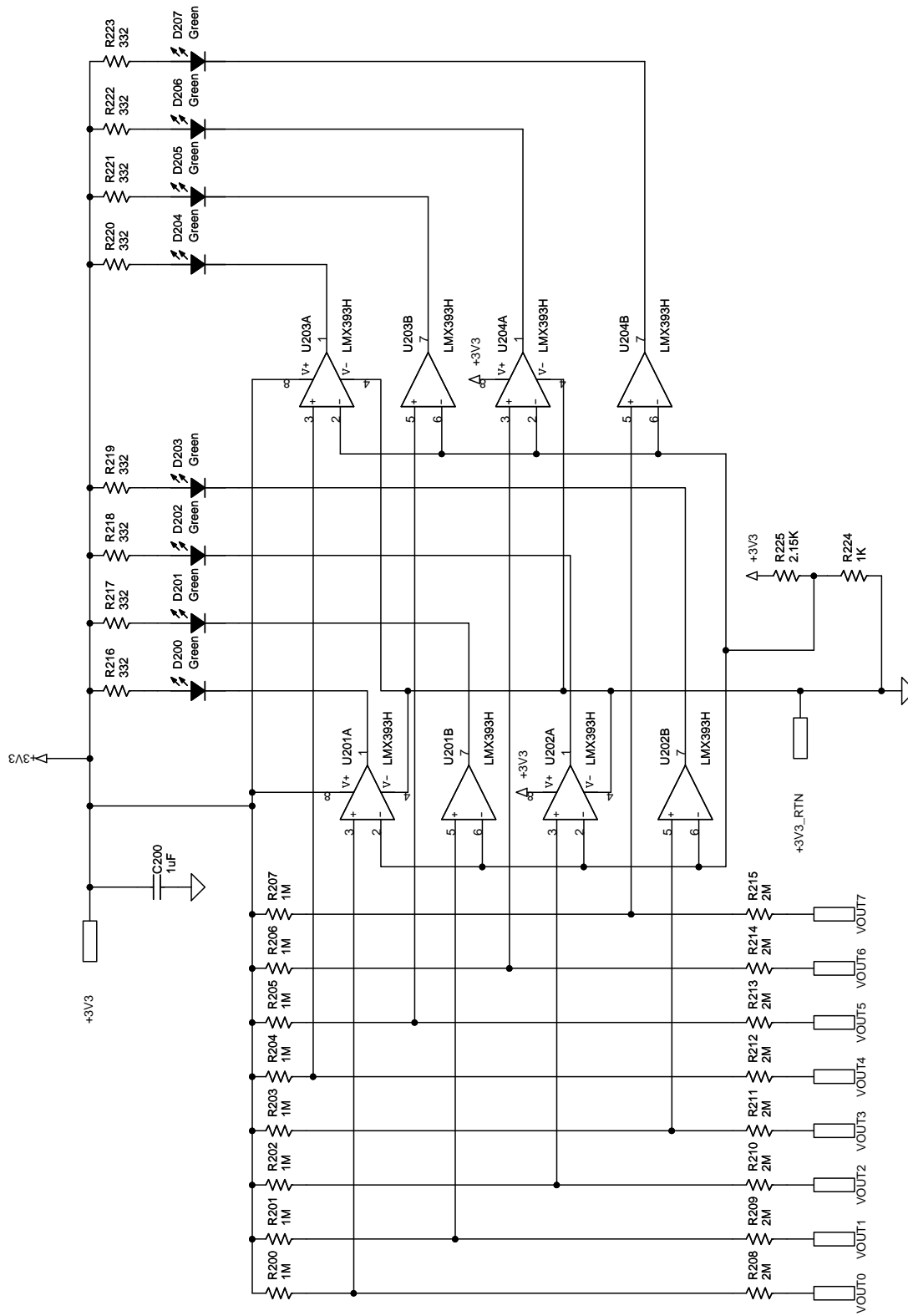

Figure 28. LED Drivers

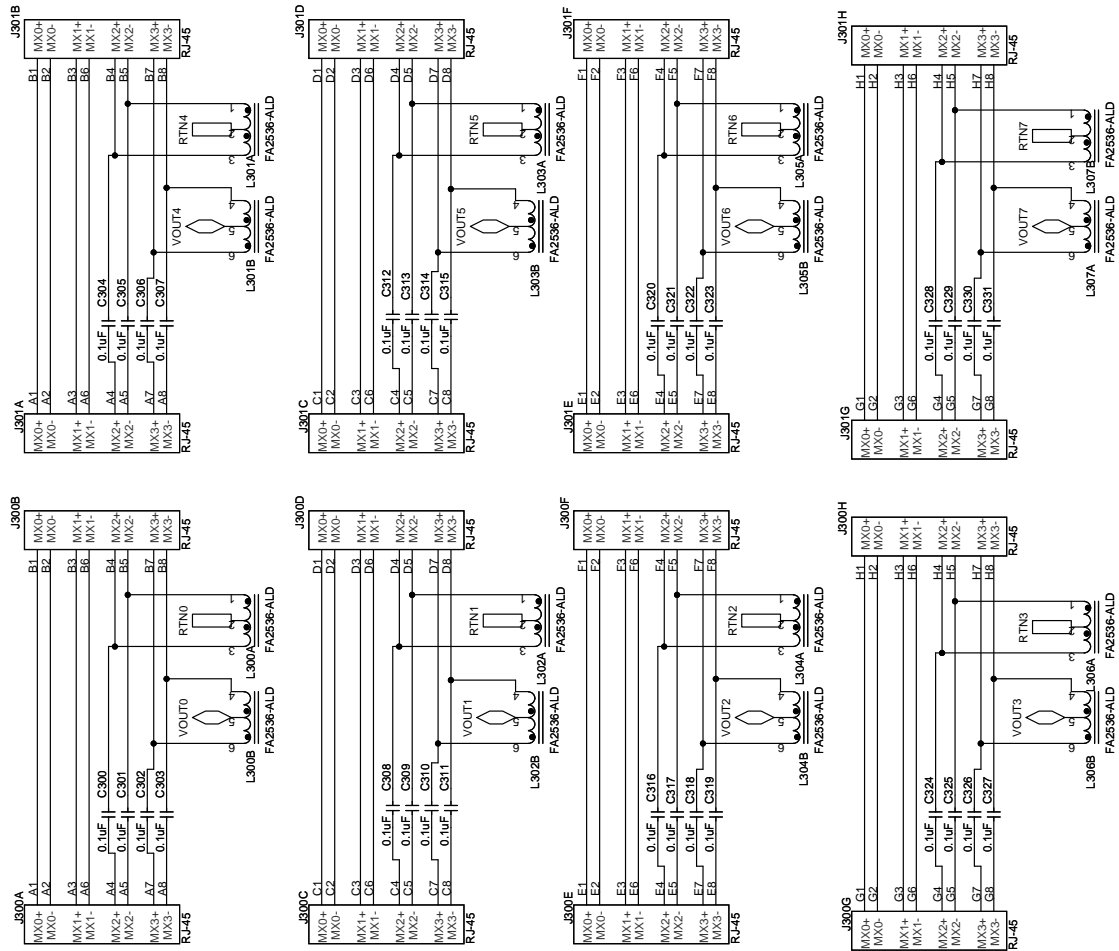

Figure 29. Connectors and Coupling Circuits

7.6. RJ45 Connector Board Layout

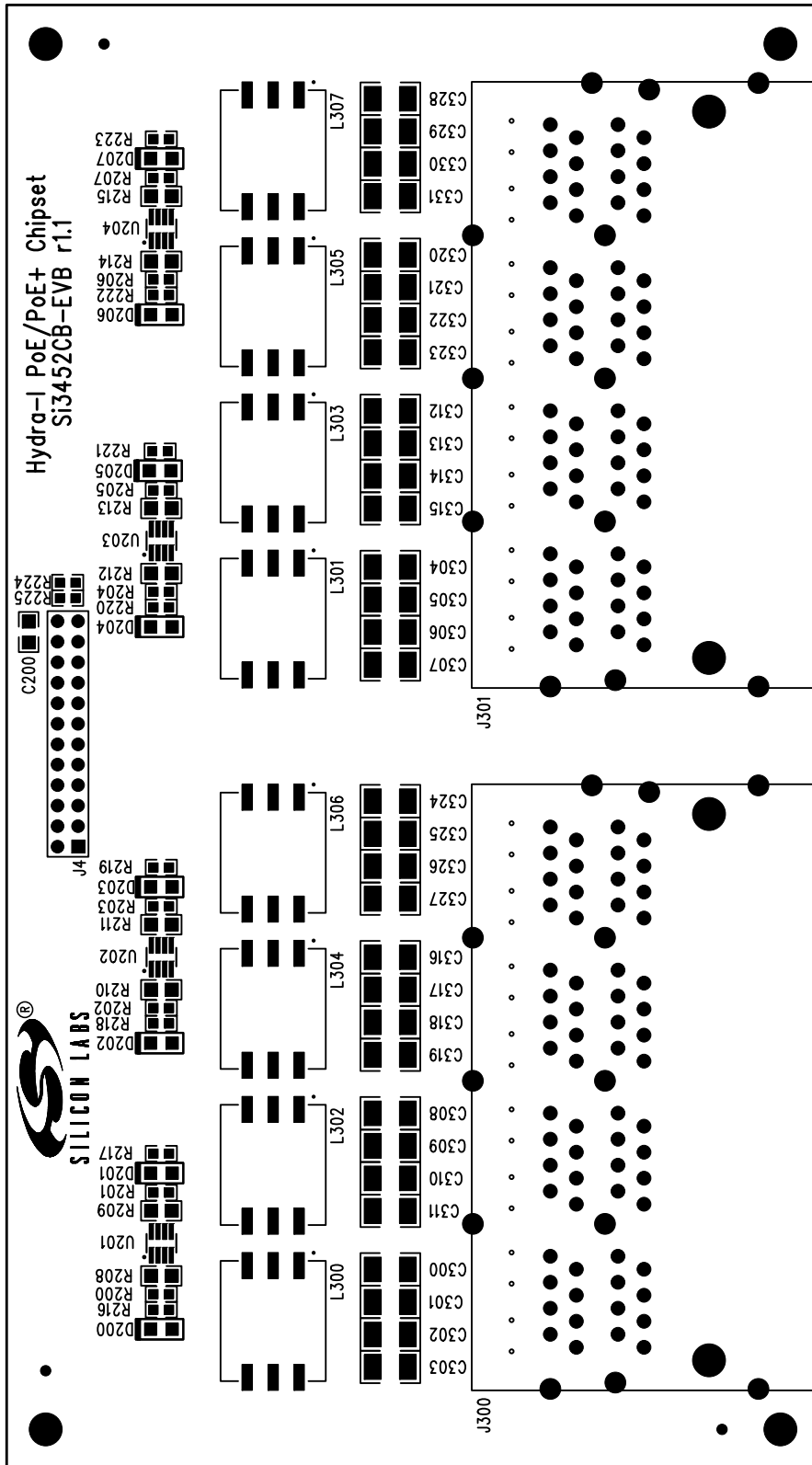

Figure 30. RJ-45 Top Silkscreen

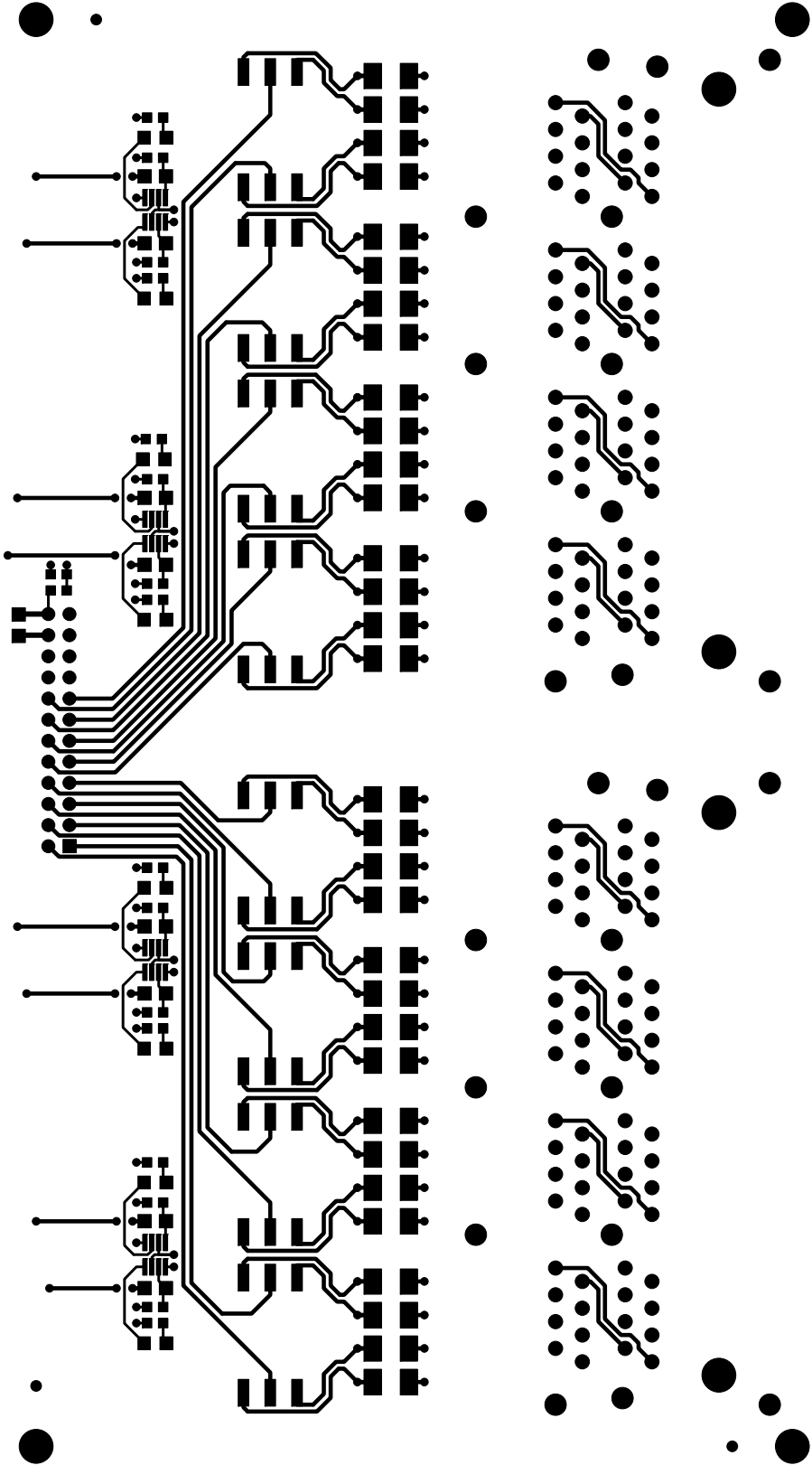

Figure 31. RJ45 Primary Side

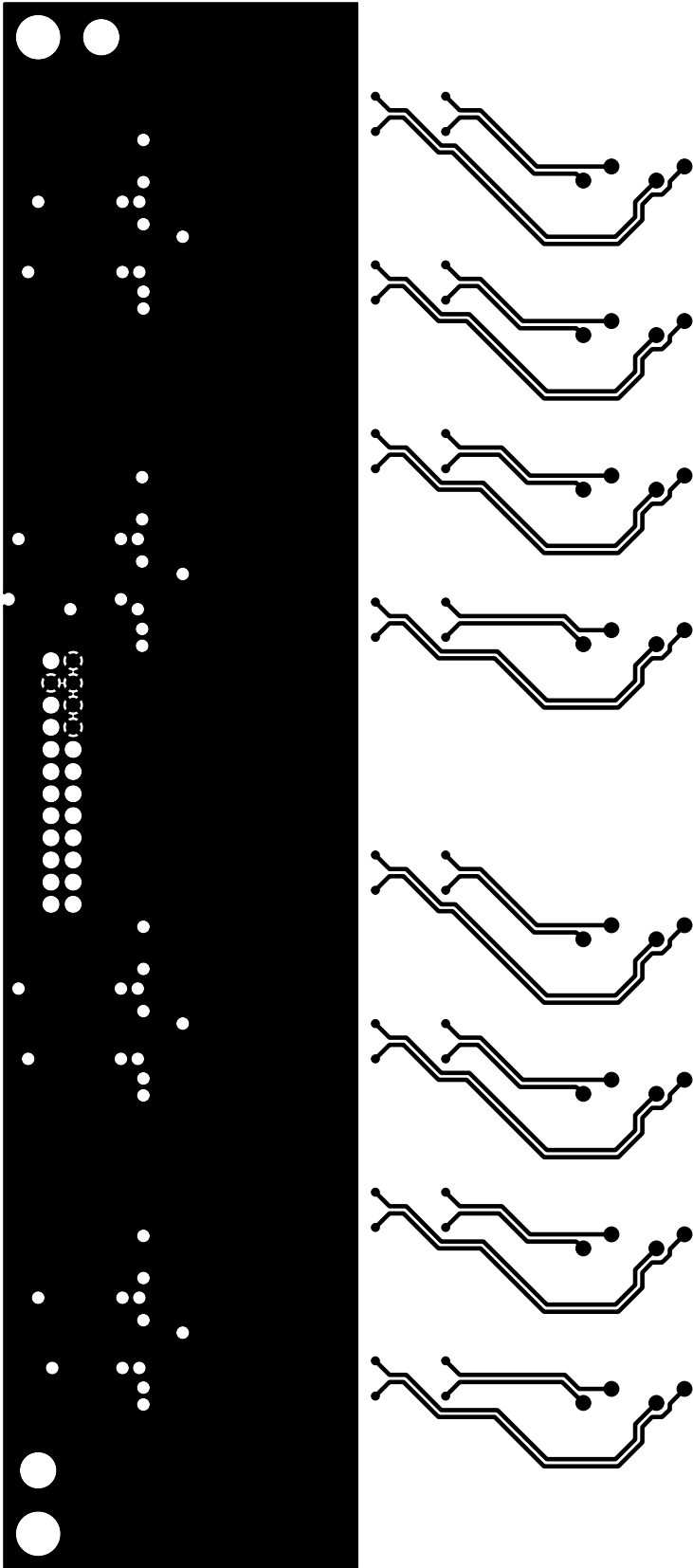

Figure 32. RJ45 Ground Plane

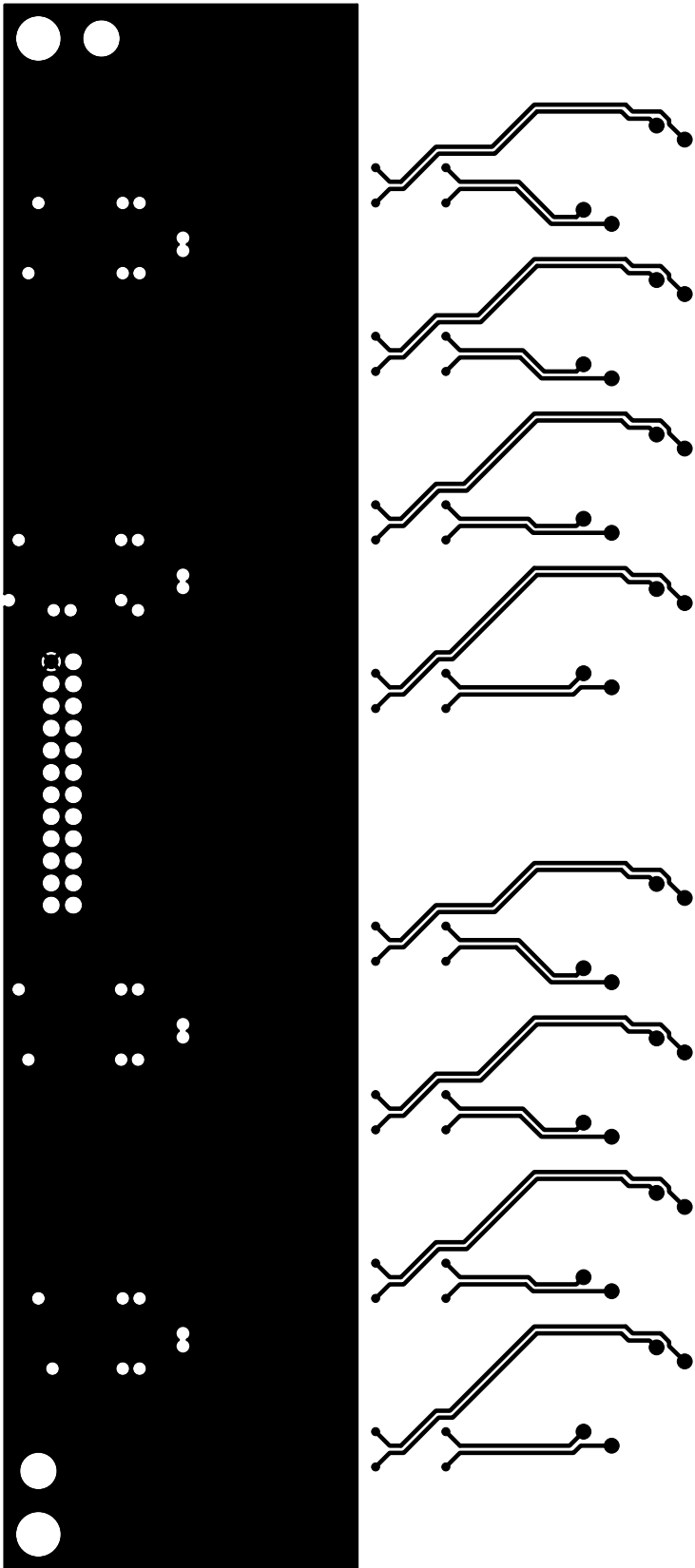

Figure 33. RJ45 Power Plane

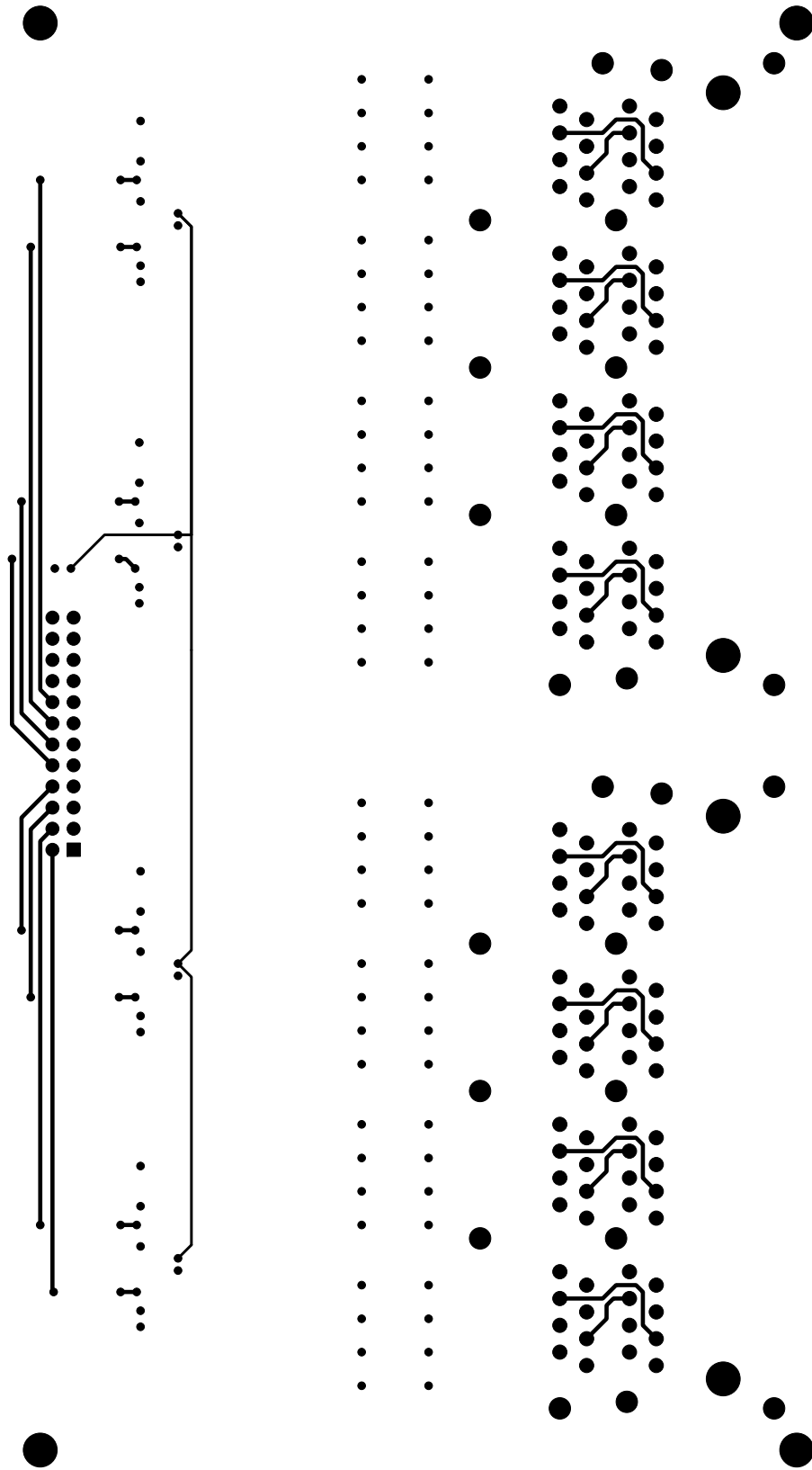

Figure 34. RJ45 Secondary Side

Si3452MS8-KIT

7.7. RJ45 Connector Board Bill of Materials

Table 3. RJ45 Bill of Materials

Item	Qty	Ref	Value	Rating	Tol	PCB Footprint	Mfr Part Number	Mfr
1	1	C200	1 μ F		\pm 20%	C0805	C0805X7R160-105M	Venkel
2	32	C300,C301,C302, C303,C304,C305, C306,C307,C308, C309,C310,C311, C312,C313,C314, C315,C316,C317, C318,C319,C320, C321,C322,C323, C324,C325,C326, C327,C328,C329, C330,C331	0.1 μ F		\pm 20%	C1210	C1210X7R251-104M	Venkel
3	8	D200,D201,D202, D203,D204,D205, D206,D207	Green	30 mA		LED-0805-K	LTST-C170GKT	LITE_ON INC
4	1	J4	CONN Header 12x2			CONN-2X12-2MM	TMM-112-01-T-D	Samtec
5	2	J300,J301	RJ-45			RJ45-8PORT	44170-0001	MOLEX
6	8	L300,L301,L302, L303,L304,L305, L306,L307	FA2536-ALD	675 μ H		FA2536-AL	FA2536-ALD	COIL- CRAFT
7	8	R200,R201,R202, R203,R204,R205, R206,R207	1 M Ω	1/16 W	\pm 1%	R0603	CR0603-16W-1004F	Venkel
8	8	R208,R209,R210, R211,R212,R213, R214,R215	2 M Ω	1/8 W	\pm 5%	R0805	CR0805-8W-205J	Venkel
9	8	R216,R217,R218, R219,R220,R221, R222,R223	332 Ω	1/10 W	\pm 1%	R0603	CR0603-10W-3320F	Venkel
10	1	R224	1 k Ω	1/16 W	\pm 1%	R0603	CR0603-16W-1001F	Venkel
11	1	R225	2.15 k Ω	1/10 W	\pm 1%	R0603	CR0603-10W-2151F	Venkel
12	4	U201,U202,U203, U204	LMX393H	714 mW		SOT23-8N	LMX393HAKA-T	MAXIM IC

8. Ordering Guide

Due to the unique high-voltage and high-power design considerations, Silicon Labs recommends that the reference designs be followed closely. Visit the Silicon Labs Technical Support web page and register to submit a technical support request, particularly if you are not closely following the recommended reference design.

Ordering Part Number	Description
Si3452MS8-KIT	Evaluation board kit for Si3452, 8-port midspan evaluation board reference design. Populated with Si3452 devices. Refer to the Si3452 data sheet Ordering Guide section for current ordering and device configuration information.
Si3452-XYX-GM	Ordering part number for Si3452 devices. X = device revision; YY = firmware revision. Refer to the Si3452 data sheet Ordering Guide section for current ordering and device configuration information.

Checking whether Driver is Installed

To check whether the driver is installed, perform the following steps:

1. Open the Control Panel and click the System icon.

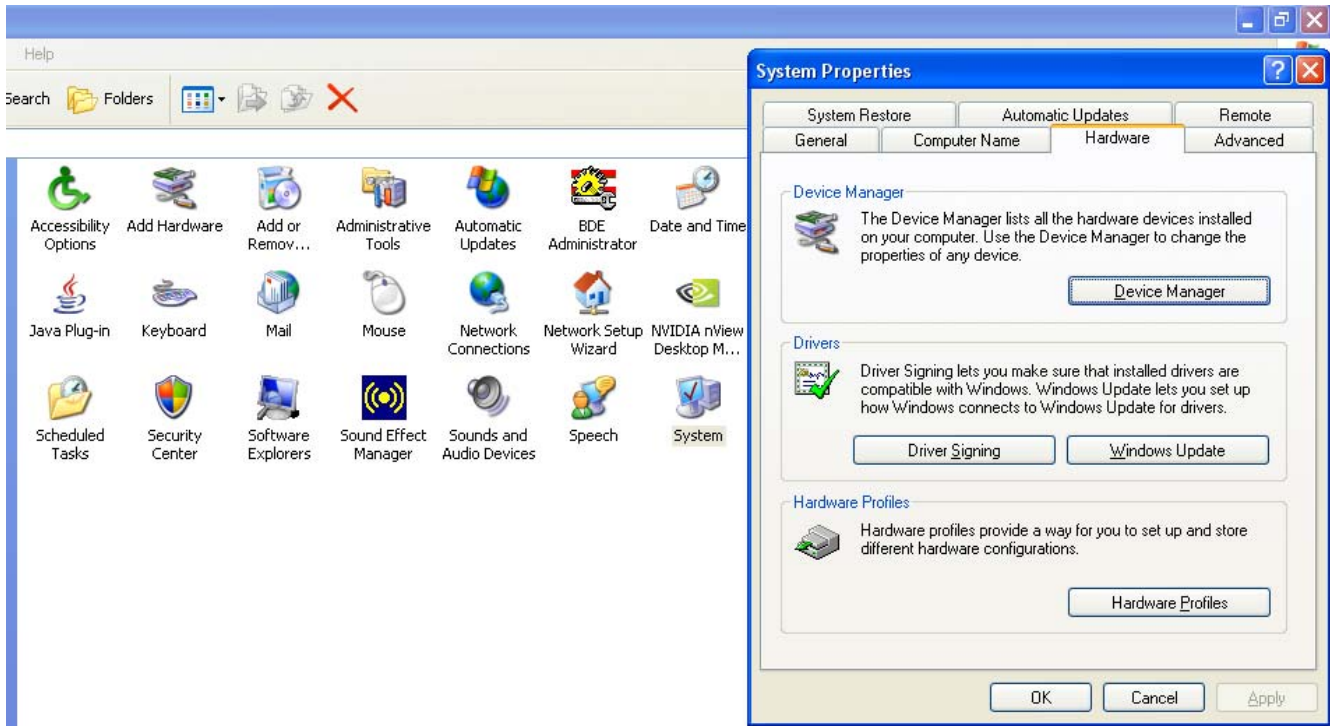

Figure 35. Control Panel

2. Select “Hardware” and click Device Manager. The screen shown in Figure 36 will appear.

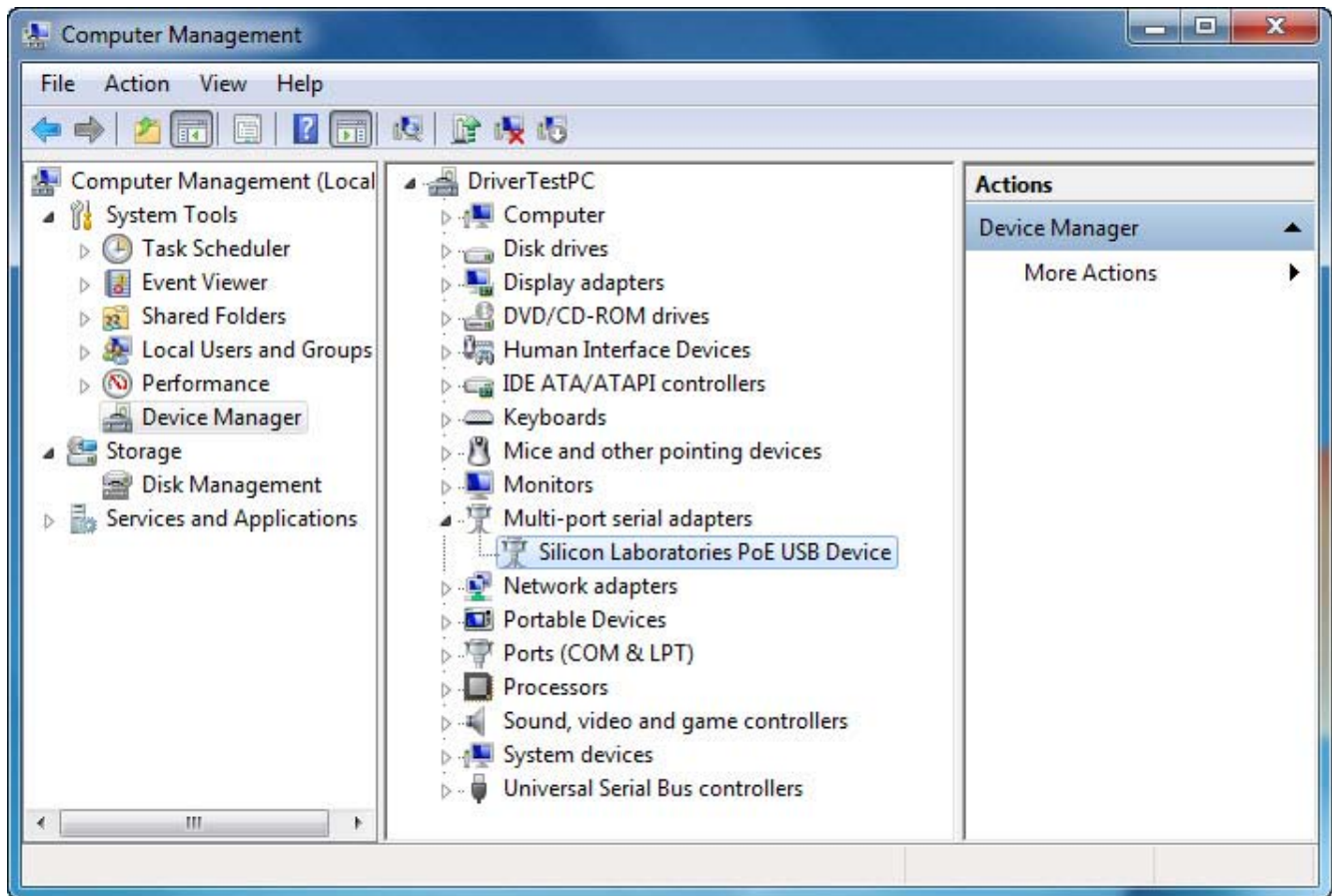

Figure 36. Device Manager

3. Click on “Multi-port serial adapters”, and, if it has installed, it will appear as “Silicon Laboratories PoE USB Device”.

DOCUMENT CHANGE LIST

Revision 0.1 to Revision 0.2

- Updated Figures 19 and 20.
 - Added schematic notes
- Editorial changes related to layout guidelines.

Revision 0.2 to Revision 0.3

- Updated "2. Kit Contents" on page 2.
- Updated Table 1.

Revision 0.3 to Revision 0.4

- Updated kit contents in Table 1 on page 2.

Revision 0.4 to Revision 0.5

- Changed document title from Si3452MS8-EVB to Si3452MS8-KIT.
- Updated "3. Installation" on page 3.
- Updated "3.1. Installing the PoUSB Device" on page 3.
- Updated "3.2. Si3452 Monitor GUI Installation" on page 5.
- Updated Figure 3 on page 5.
- Updated "Uninstalling the Si3452 Monitor GUI" on page 37.

Revision 0.5 to Revision 0.6

- Updated Table 1 on page 2.
- Revised "3. Installation" on page 3.
- Updated "4. Hardware Installation" on page 5.
- Updated Figure 5 on page 5.
- Deleted Figure 6.
- Revised "5. Using the Si3452 Monitor" on page 7.
- Updated "6. Operating the System" on page 14.
- Updated Figure 18 on page 14.
- Updated "Appendix" on page 36.
- Updated Figure 36 on page 37.
- Removed "Uninstalling the USB to I²C Driver" section.
- Removed "Uninstalling the Si3452 Monitor GUI" section.

NOTES:

Si3452MS8-KIT

CONTACT INFORMATION

Silicon Laboratories Inc.
400 West Cesar Chavez
Austin, TX 78701
Tel: 1+(512) 416-8500
Fax: 1+(512) 416-9669
Toll Free: 1+(877) 444-3032

Please visit the Silicon Labs Technical Support web page:
<https://www.silabs.com/support/pages/contacttechnicalsupport.aspx>
and register to submit a technical support request.

The information in this document is believed to be accurate in all respects at the time of publication but is subject to change without notice. Silicon Laboratories assumes no responsibility for errors and omissions, and disclaims responsibility for any consequences resulting from the use of information included herein. Additionally, Silicon Laboratories assumes no responsibility for the functioning of undescribed features or parameters. Silicon Laboratories reserves the right to make changes without further notice. Silicon Laboratories makes no warranty, representation or guarantee regarding the suitability of its products for any particular purpose, nor does Silicon Laboratories assume any liability arising out of the application or use of any product or circuit, and specifically disclaims any and all liability, including without limitation consequential or incidental damages. Silicon Laboratories products are not designed, intended, or authorized for use in applications intended to support or sustain life, or for any other application in which the failure of the Silicon Laboratories product could create a situation where personal injury or death may occur. Should Buyer purchase or use Silicon Laboratories products for any such unintended or unauthorized application, Buyer shall indemnify and hold Silicon Laboratories harmless against all claims and damages.

Silicon Laboratories and Silicon Labs are trademarks of Silicon Laboratories Inc.
Other products or brandnames mentioned herein are trademarks or registered trademarks of their respective holders.